

# OWNER'S MANUAL

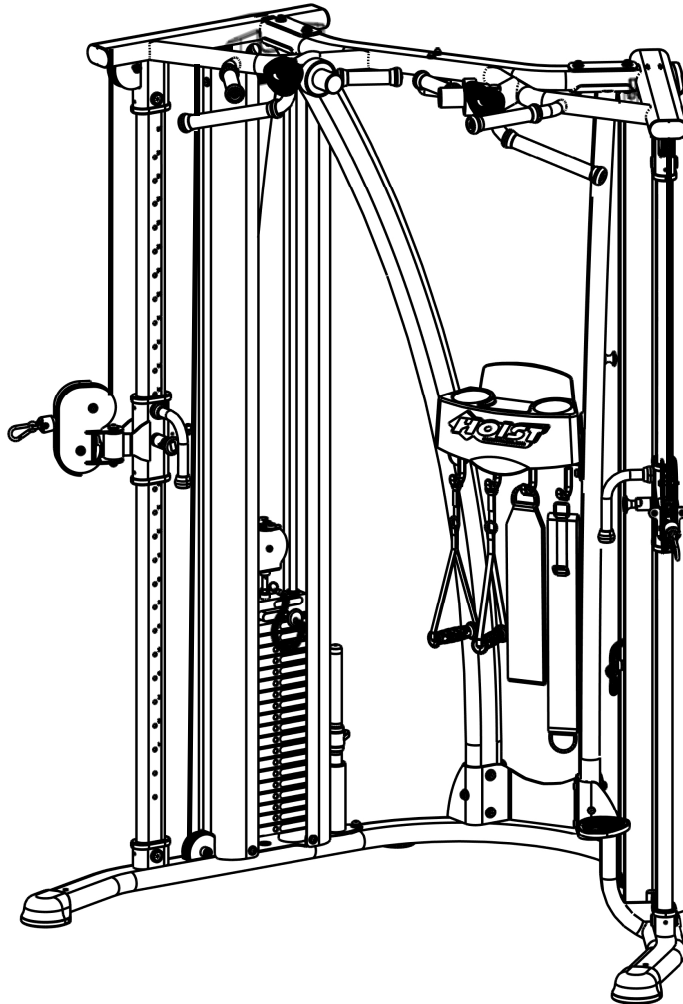

## HD-3000 PERSONAL PULLEY



### **\*\*WARNING!\*\***

TO PREVENT POSSIBLE TIPPING, BOLT THIS UNIT TO THE EXERCISE FLOOR.  
FAILURE TO DO SO MAY RESULT IN SERIOUS INJURY OR DEATH.

**Note: Both Serial Number and Model Number are Required when Ordering Parts**

**RECORD SERIAL NUMBER HERE**

**MACHINE CODE**

**Customer Service**

(800) 548-5438

(858) 578-7676

**Fax**

(858) 578-9558



[www.facebook.com/hoistfitness](http://www.facebook.com/hoistfitness)

# OWNER'S MANUAL

## CONTENTS

INSTRUCTIONS.....	02
FRAME ASSEMBLY.....	04
PRE-ASSEMBLY.....	21
DECAL PLACEMENT.....	24
ACCESSORIES.....	25
BOLTING TO THE FLOOR.....	26
DECAL REFERENCE.....	27
PART LIST.....	30
ABBREVIATIONS.....	34
BOLT SIZING CHART.....	35
WASHER SIZING CHART.....	36
MAINTENANCE SCHEDULE.....	38
GENERAL MAINTENANCE INFORMATION.....	39
WEIGHT TRAINING TIPS.....	40
WEIGHT RATIOS.....	41
EXERCISE LOG.....	42
LIMITED WARRANTY.....	43



# **OWNER'S MANUAL**

## **INSTRUCTIONS**

Before beginning assembly please take the time to read instructions thoroughly. Please use the various lists in this manual to make sure that all parts have been included in your shipment. When ordering, use part number and description from the lists. Use only HOIST replacement parts when servicing. Failure to do so will void your warranty and could result in personal injury.

HOIST equipment is designed to provide the smoothest, most effective exercise motion possible. After assembly, you should check all functions to ensure correct operation. If you experience problems, first recheck the assembly instructions to locate any possible errors made during assembly. If you are unable to correct the problem, call your authorized HOIST dealer. Be sure to have your serial number and this manual when calling. When all parts have been accounted for, continue on.

## **TOOLS REQUIRED**

**Ratchet Wrench**

**1/2", 9/16" and 3/4" Sockets**

**Adjustable Wrench**

**Rubber Mallet**

**Tape Measure**

**Level**

**SAE Hex Key Wrench Set**

**Two People**

# **OWNER'S MANUAL**

**\*\*\*THIS PAGE WAS INTENTIONALLY LEFT BLANK\*\*\***

# OWNER'S MANUAL

## FRAME ASSEMBLY

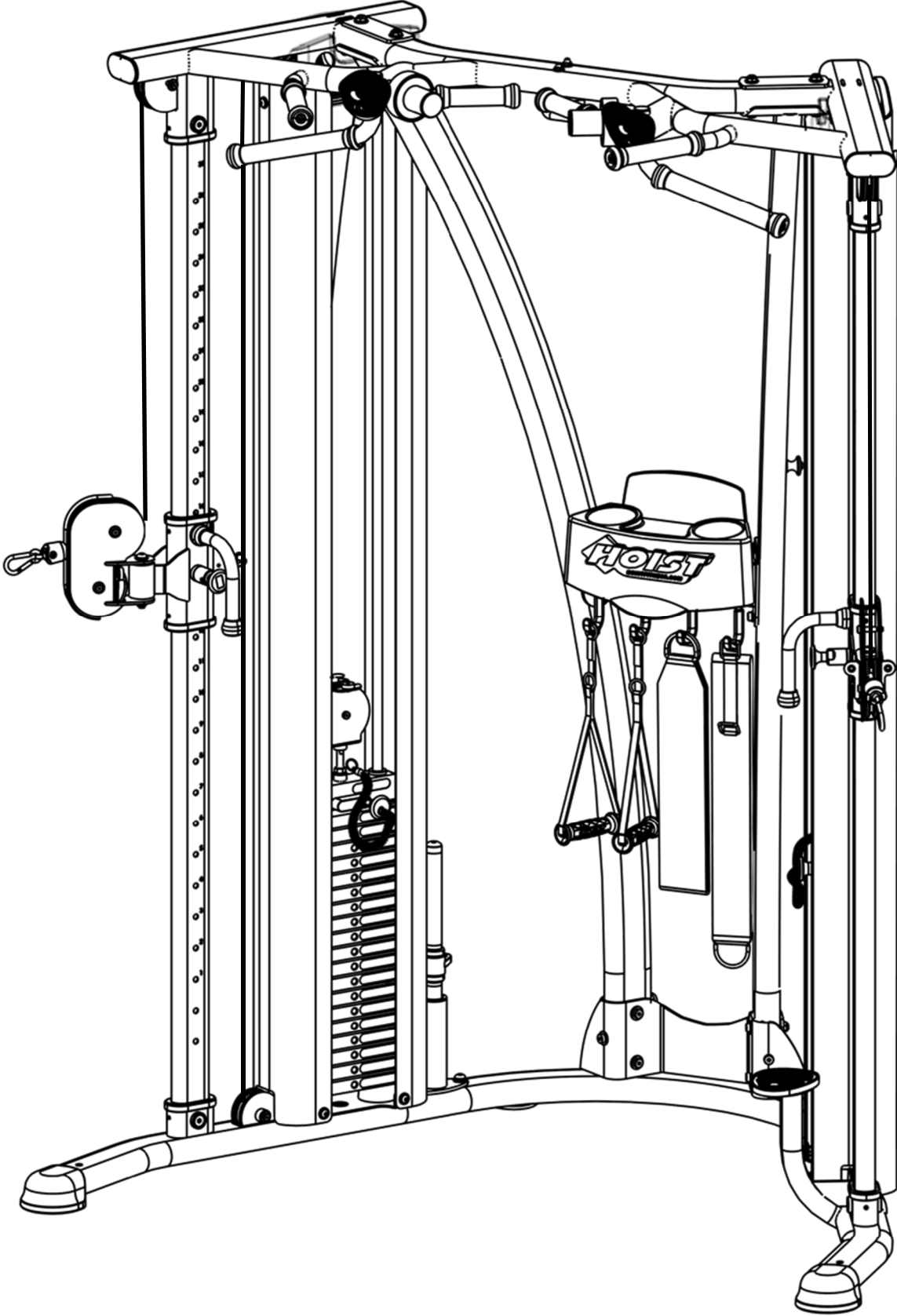

# OWNER'S MANUAL

## FRAME ASSEMBLY

NOTE:

- HAND TIGHTEN HARDWARE.
- SOME PARTS MAY HAVE BEEN REMOVED FOR CLARITY.

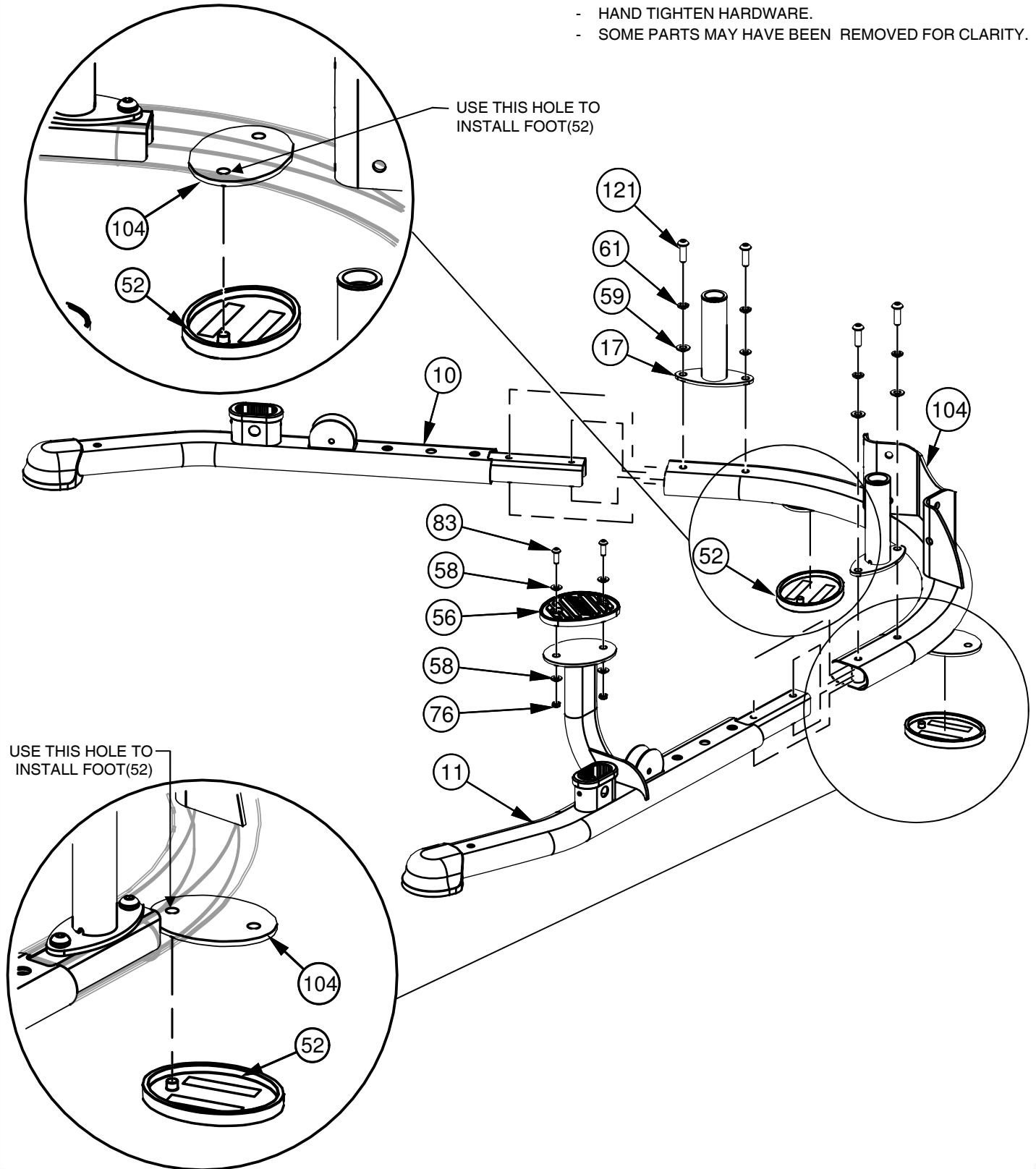

# OWNER'S MANUAL

## FRAME ASSEMBLY

NOTE:

- HAND TIGHTEN HARDWARE.
- REPEAT STEPS FOR OPPOSITE SIDE OF HD-3000
- SOME PARTS MAY HAVE BEEN REMOVED FOR CLARITY.

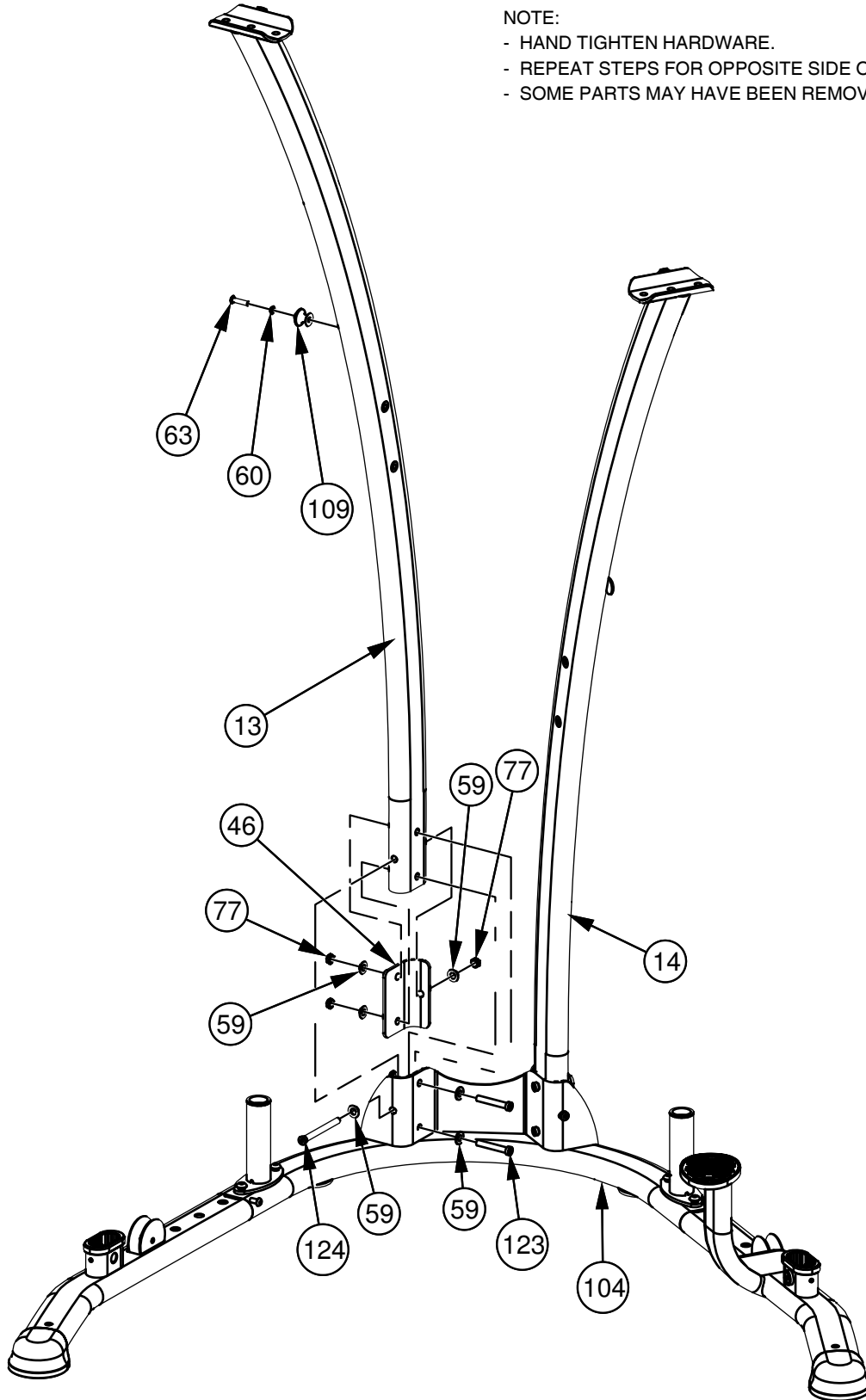

# OWNER'S MANUAL

## FRAME ASSEMBLY

NOTE:

- HAND TIGHTEN HARDWARE.
- REPEAT STEPS FOR OPPOSITE SIDE OF HD-3000
- SOME PARTS MAY HAVE BEEN REMOVED FOR CLARITY.

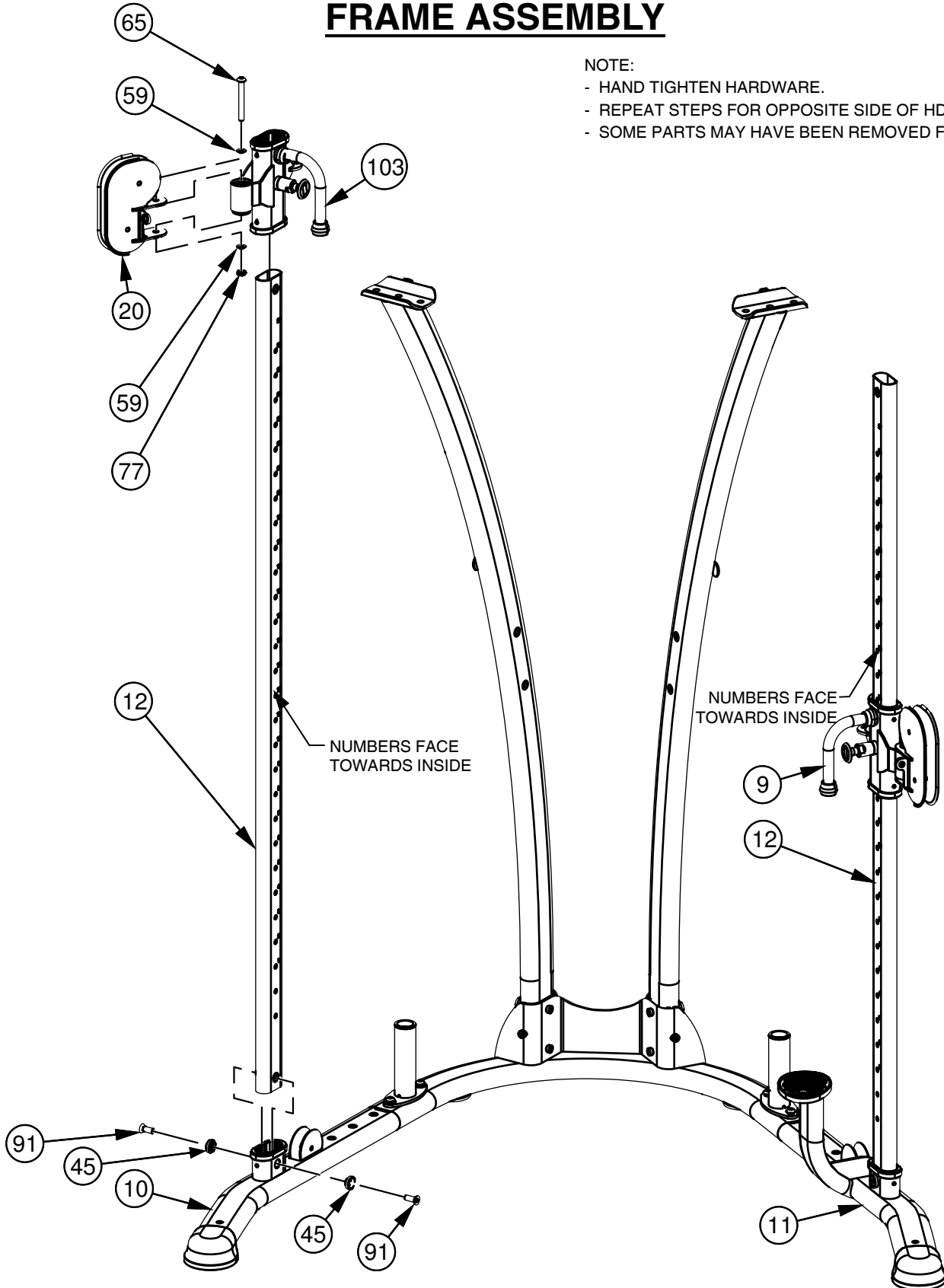

# OWNER'S MANUAL

## FRAME ASSEMBLY

NOTE:

- HAND TIGHTEN HARDWARE.
- REPEAT STEPS FOR OPPOSITE SIDE OF HD-3000
- SOME PARTS MAY HAVE BEEN REMOVED FOR CLARITY.

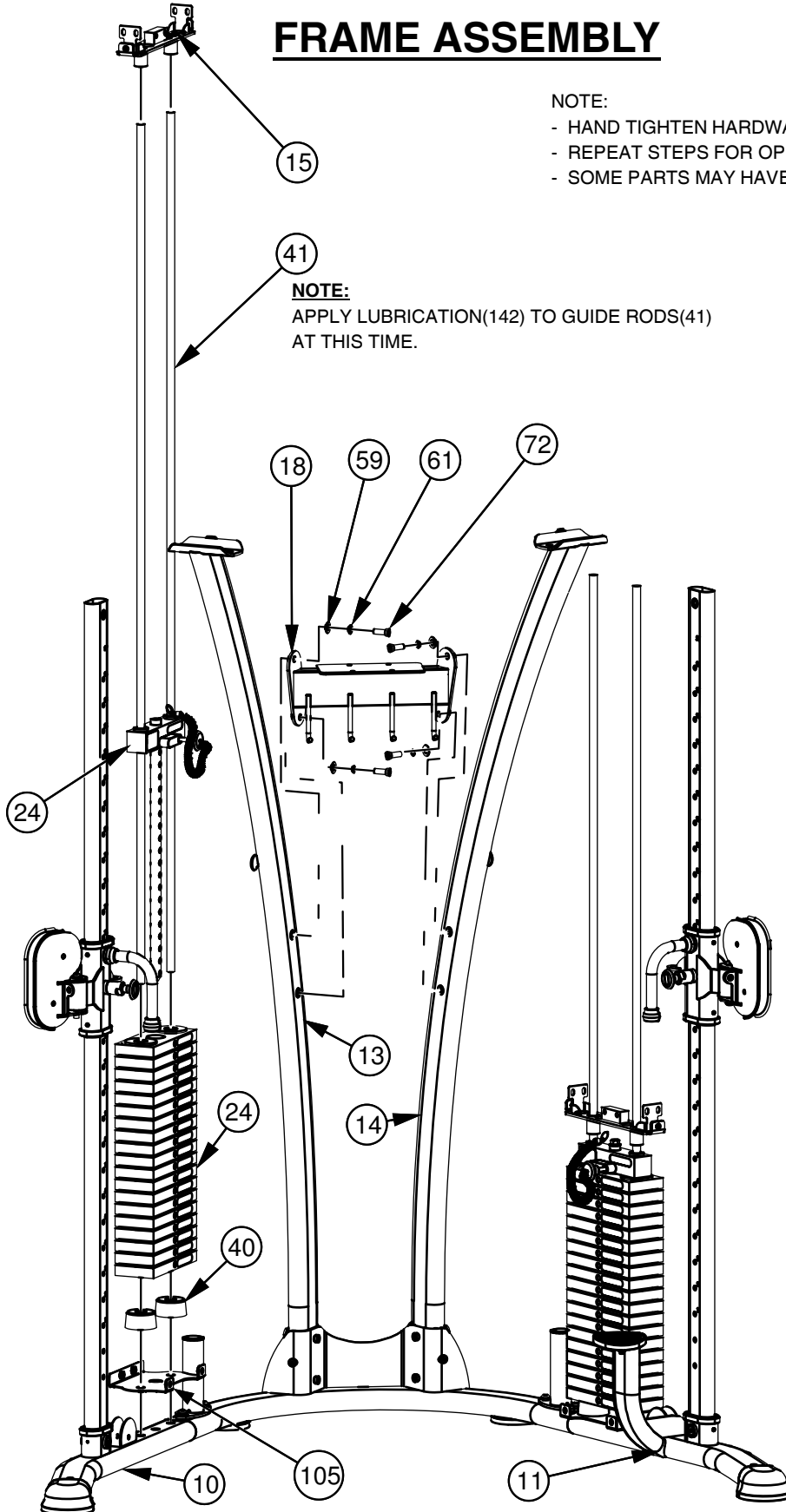

# OWNER'S MANUAL

## FRAME ASSEMBLY

NOTE:

- HAND TIGHTEN HARDWARE.
- SOME PARTS MAY HAVE BEEN REMOVED FOR CLARITY.

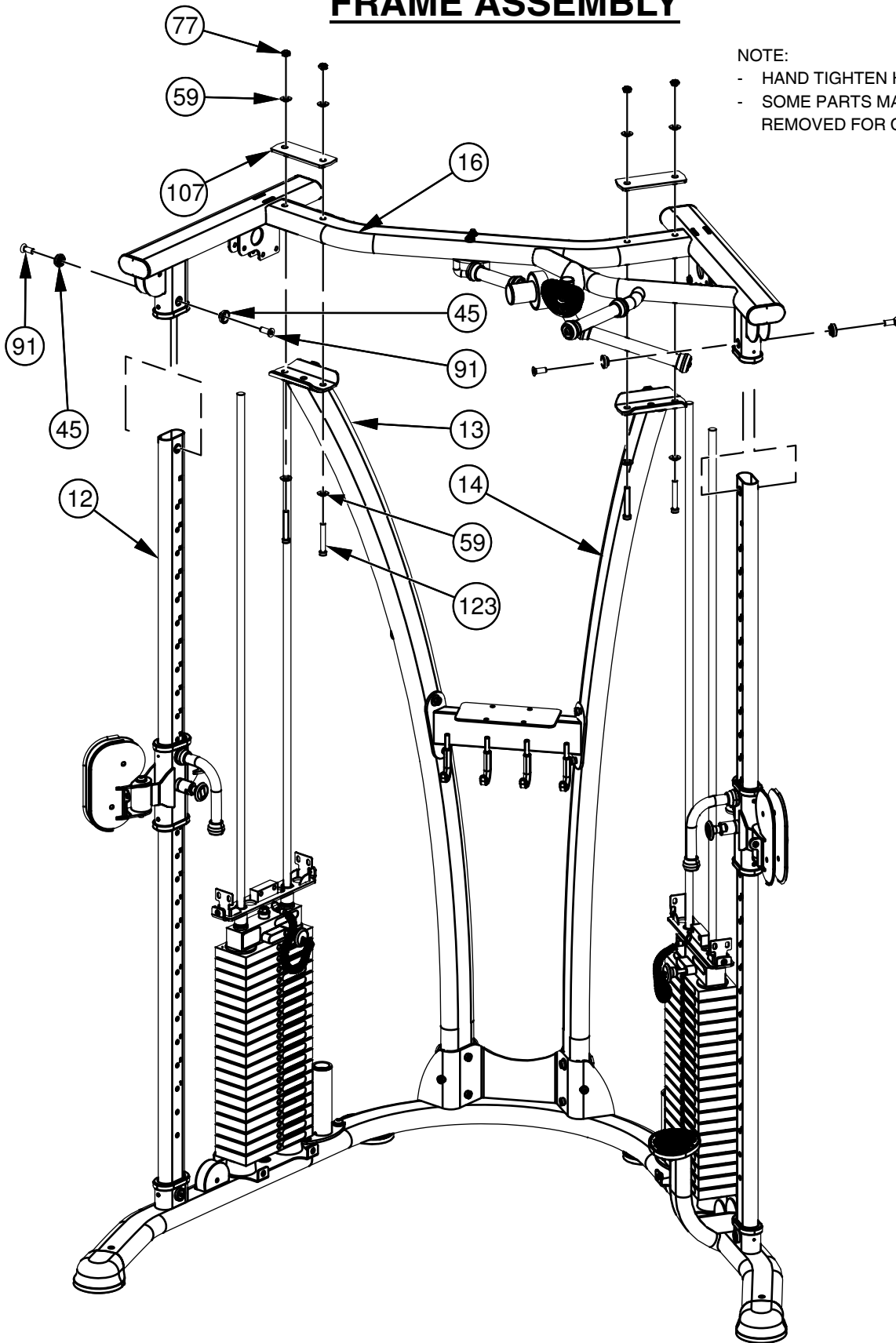



# OWNER'S MANUAL

## FRAME ASSEMBLY

CABLE REFERENCE VIEW

NOTE:

- SOME PARTS MAY HAVE BEEN REMOVED FOR CLARITY.

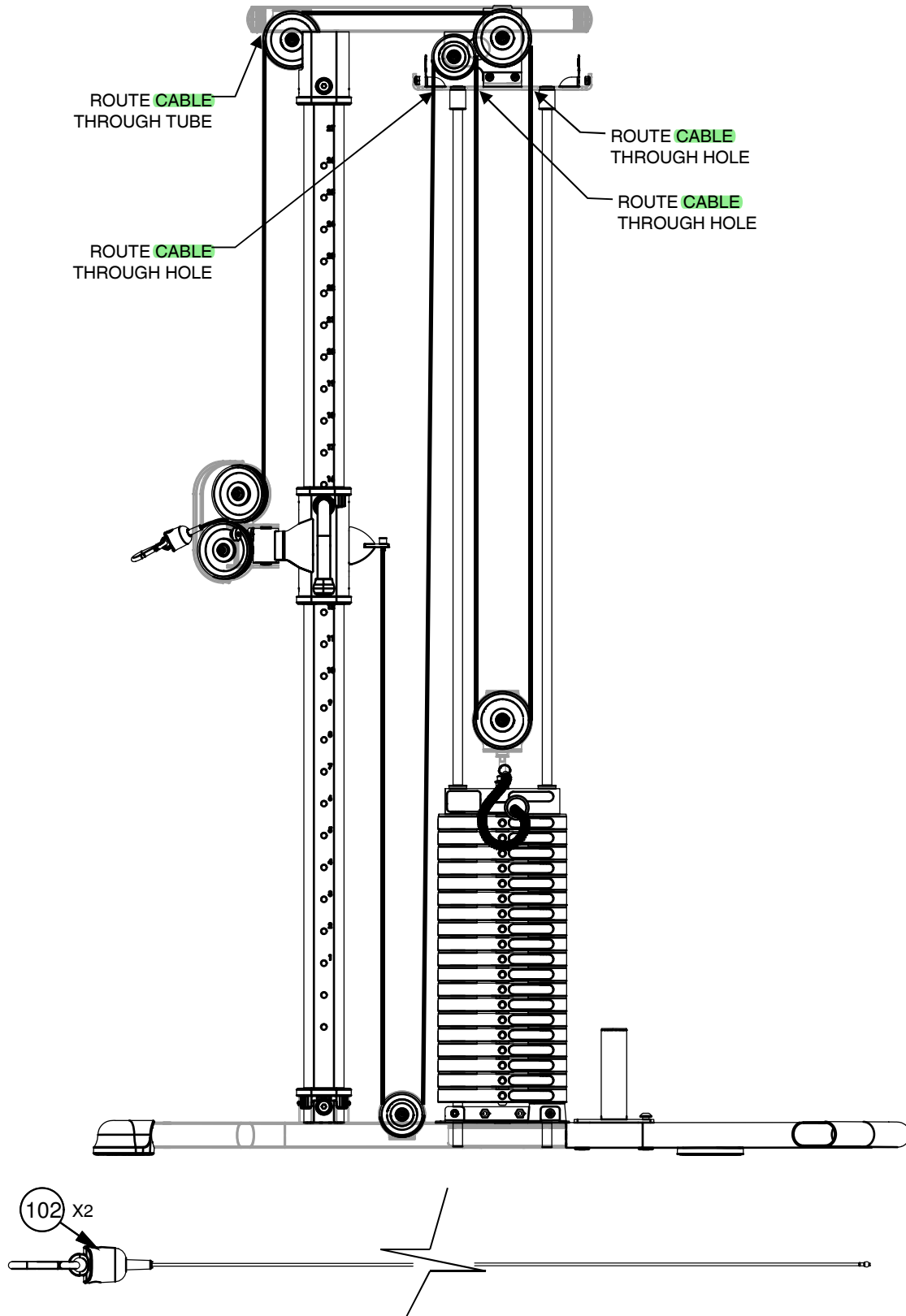

# OWNER'S MANUAL

## FRAME ASSEMBLY

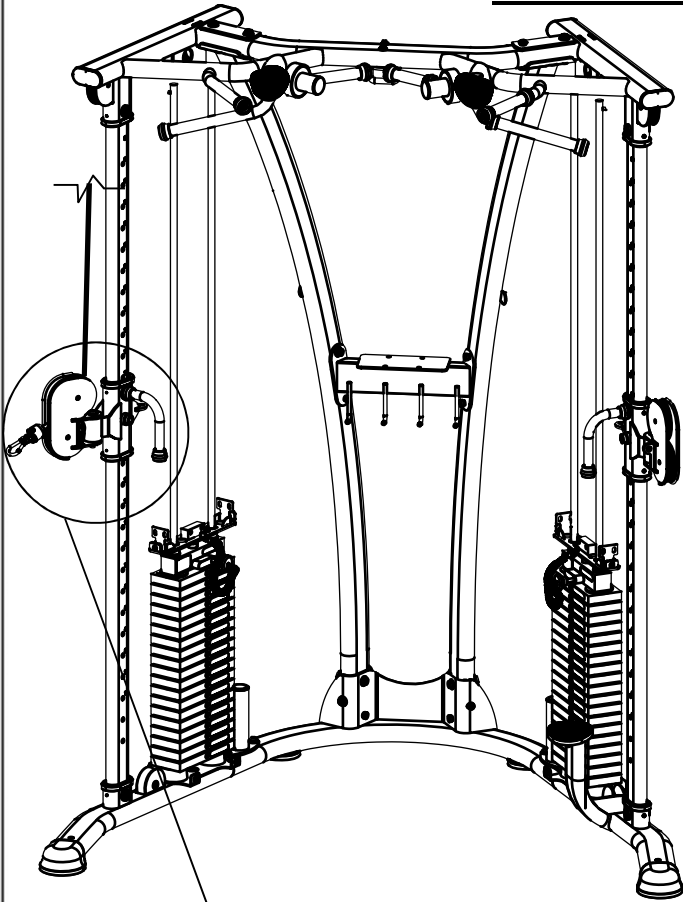

NOTE:

- WRENCH TIGHTEN HARDWARE.
- INSTALL **CABLE** AND PULLEYS AT THE SAME TIME.
- REPEAT STEPS FOR OPPOSITE SIDE OF HD-3000
- SOME PARTS MAY HAVE BEEN REMOVED FOR CLARITY.

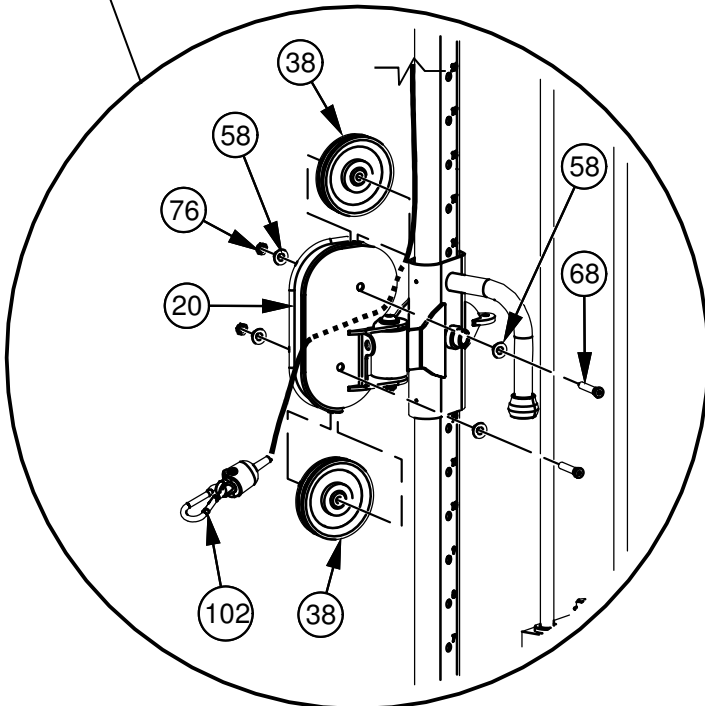

# OWNER'S MANUAL

## FRAME ASSEMBLY

NOTE:

- WRENCH TIGHTEN HARDWARE.
- INSTALL **CABLE** AND PULLEYS AT THE SAME TIME.
- REPEAT STEPS FOR OPPOSITE SIDE OF HD-3000
- SOME PARTS MAY HAVE BEEN REMOVED FOR CLARITY.

### **CABLE ROUTING VIEW**

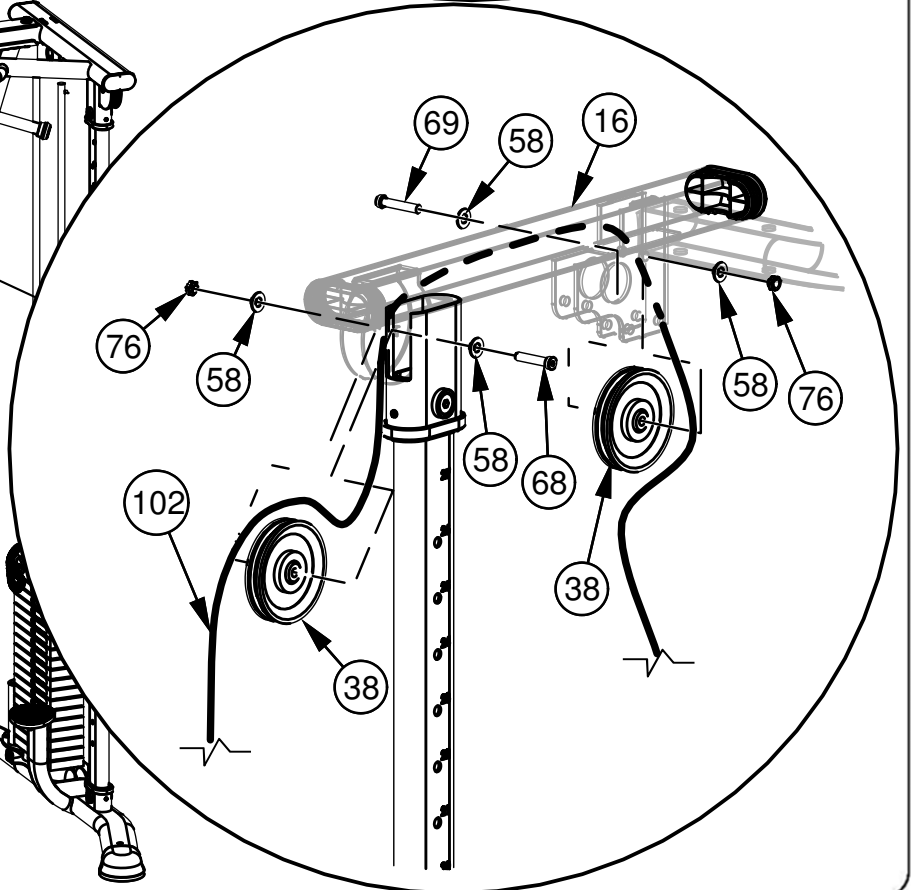
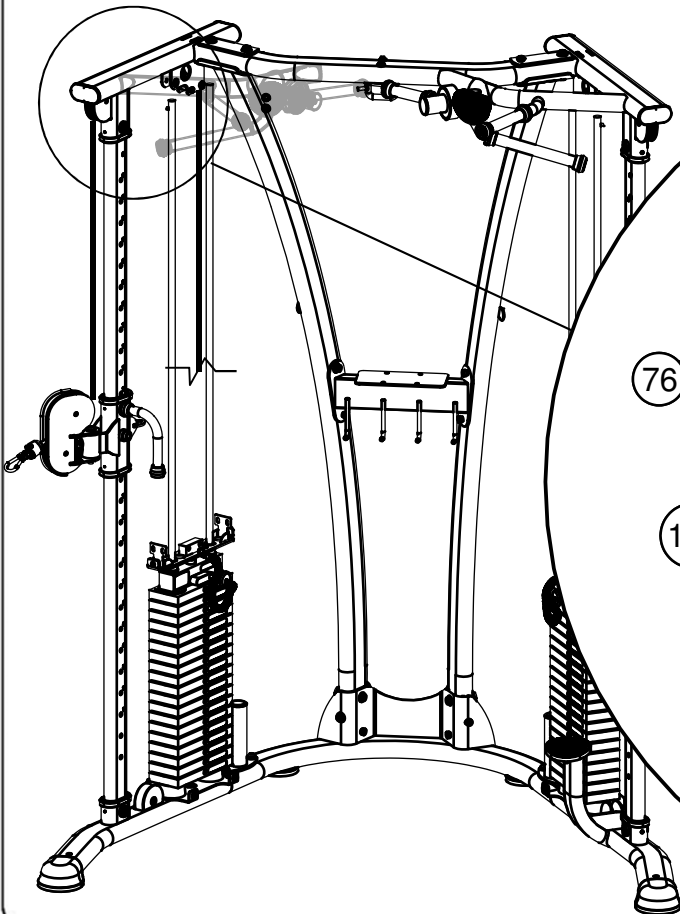
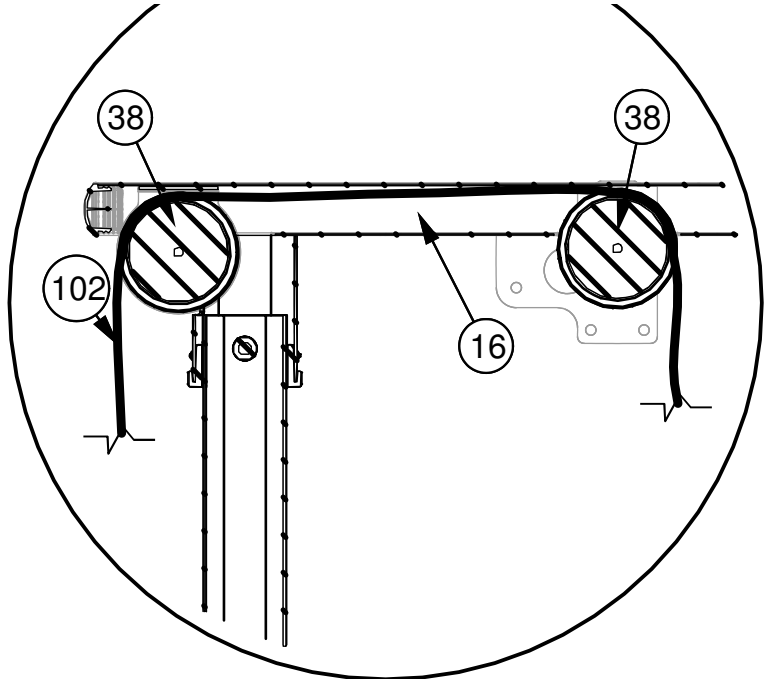

# OWNER'S MANUAL

## FRAME ASSEMBLY

NOTE:

- WRENCH TIGHTEN HARDWARE ON PULLEYS ONLY.
- INSTALL **CABLE** AND PULLEYS AT THE SAME TIME.
- REPEAT STEPS FOR OPPOSITE SIDE OF HD-3000
- SOME PARTS MAY HAVE BEEN REMOVED FOR CLARITY.

HOLD GUIDE ROD TOP BRACKET(15) UP DURING THE STEPS ON THIS PAGE. AFTER THE STEPS ARE COMPLETE, REST THE GUIDE ROD TOP BRACKET(15) ON THE ADJUSTABLE PULLEY MOUNT(21)

ROUTE **CABLE** THROUGH HOLE

ROUTE **CABLE** THROUGH HOLE

ROUTE **CABLE** THROUGH HOLE

NOTE:

- INSERT PULLPIN RING(24) BETWEEN JAM NUTS (27)

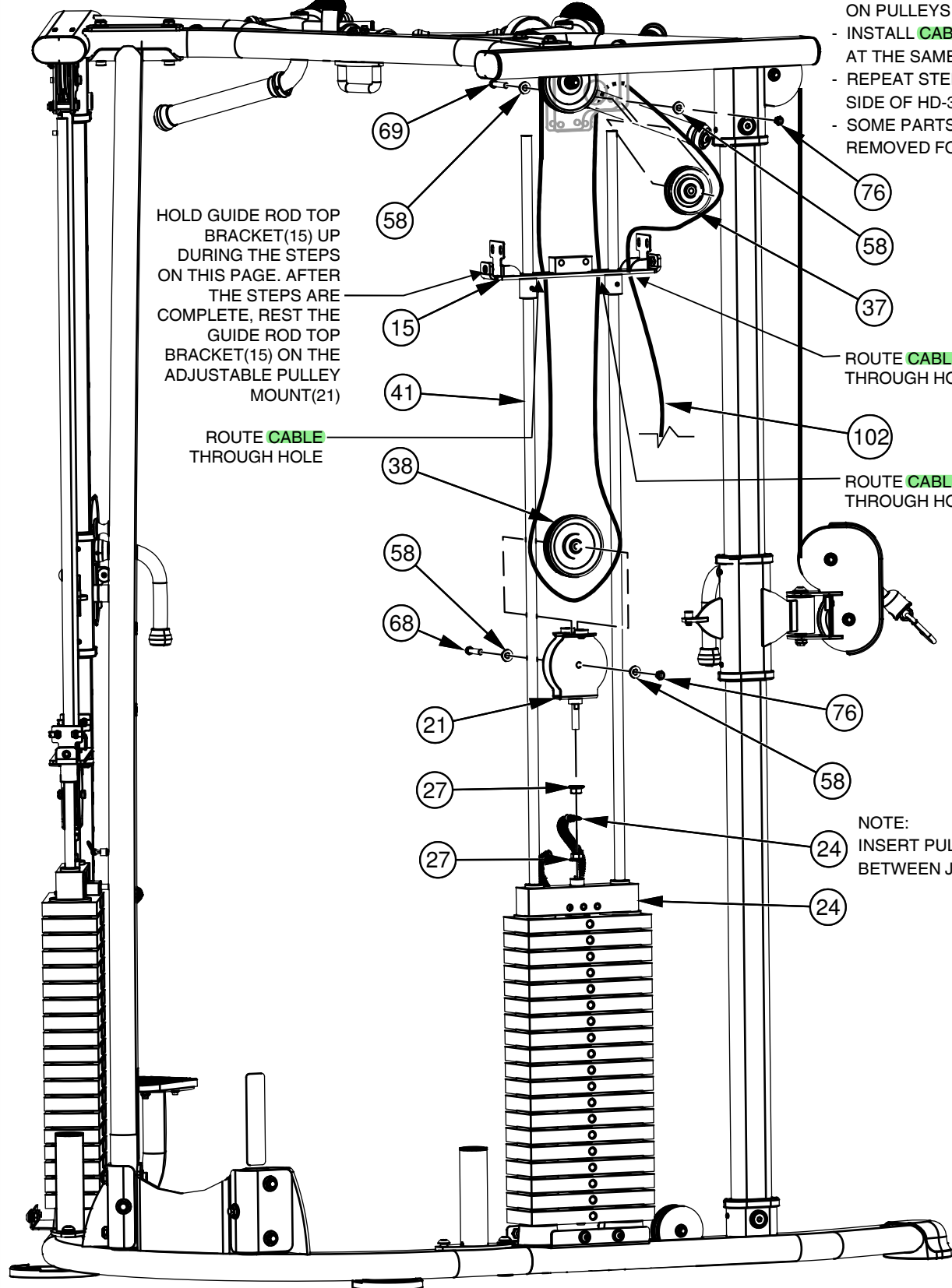

# OWNER'S MANUAL

## FRAME ASSEMBLY

NOTE:

- HAND TIGHTEN HARDWARE ON PULLEYS ONLY.
- INSTALL **CABLE** AND PULLEYS AT THE SAME TIME.
- REPEAT STEPS FOR OPPOSITE SIDE OF HD-3000
- SOME PARTS MAY HAVE BEEN REMOVED FOR CLARITY.

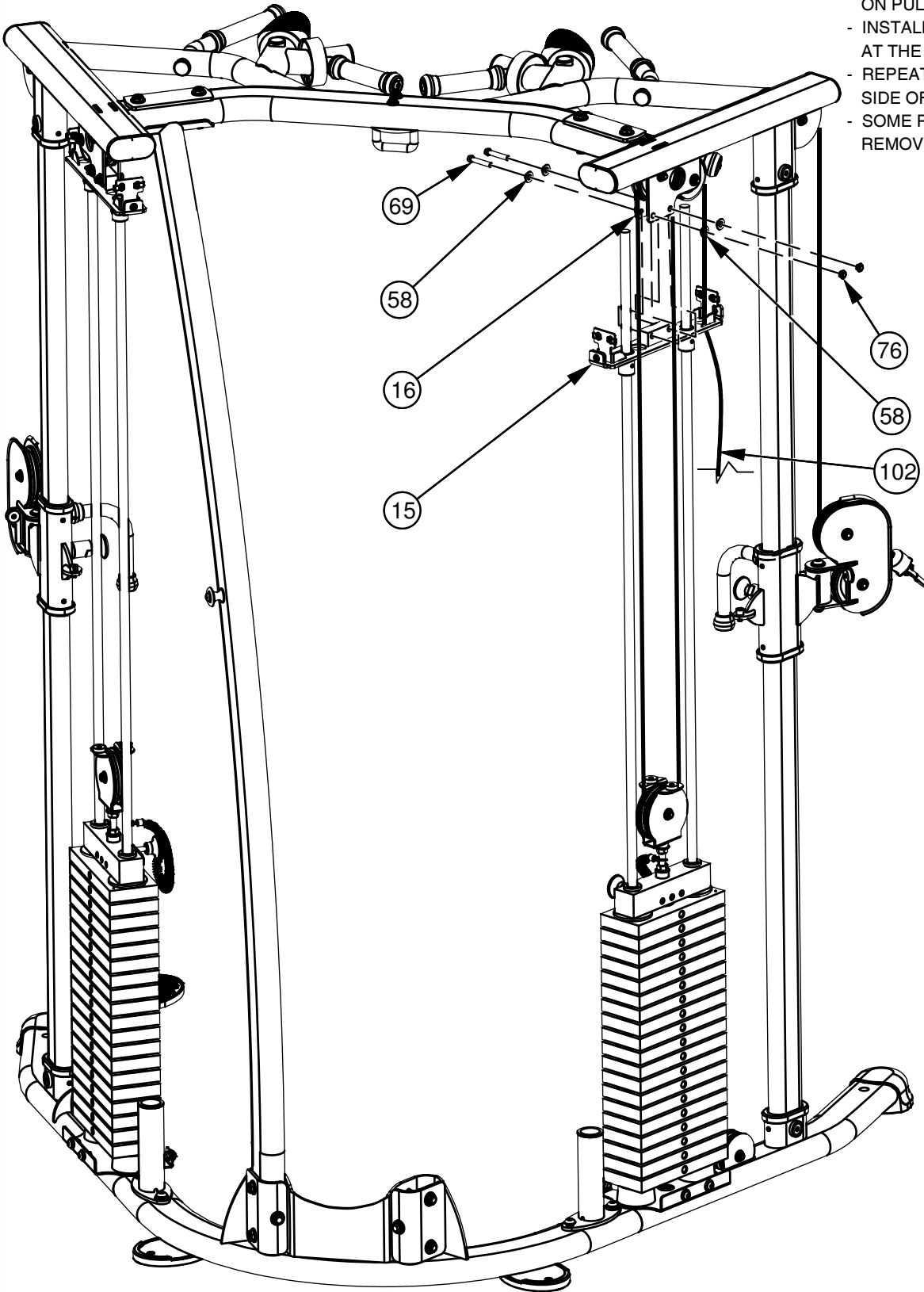

# OWNER'S MANUAL

## FRAME ASSEMBLY

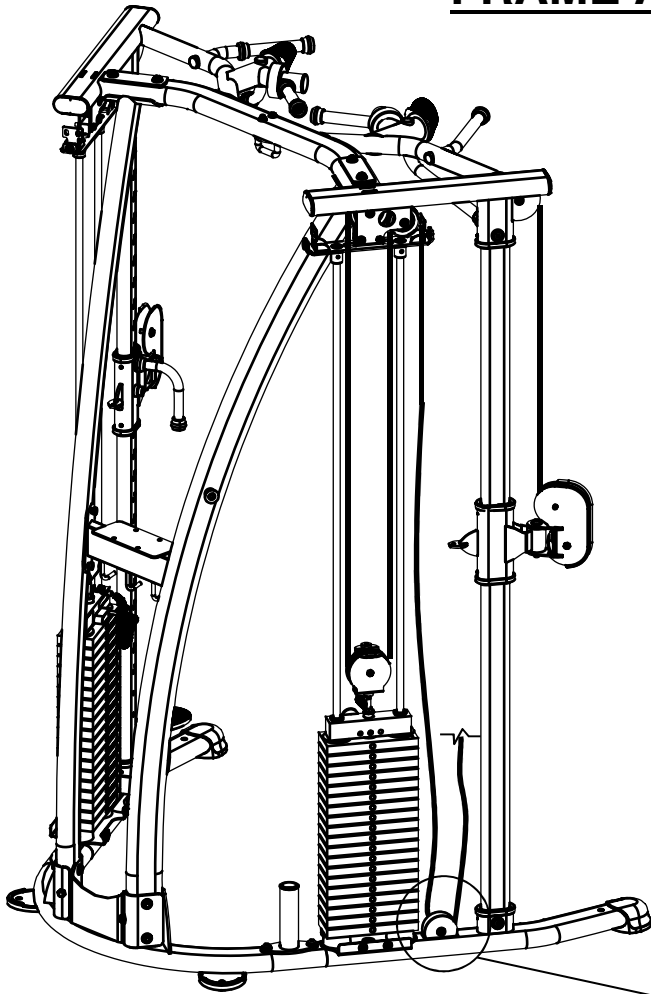

NOTE:

- WRENCH TIGHTEN HARDWARE.
- INSTALL **CABLE** AND PULLEYS AT THE SAME TIME.
- REPEAT STEPS FOR OPPOSITE SIDE OF HD-3000
- SOME PARTS MAY HAVE BEEN REMOVED FOR CLARITY.

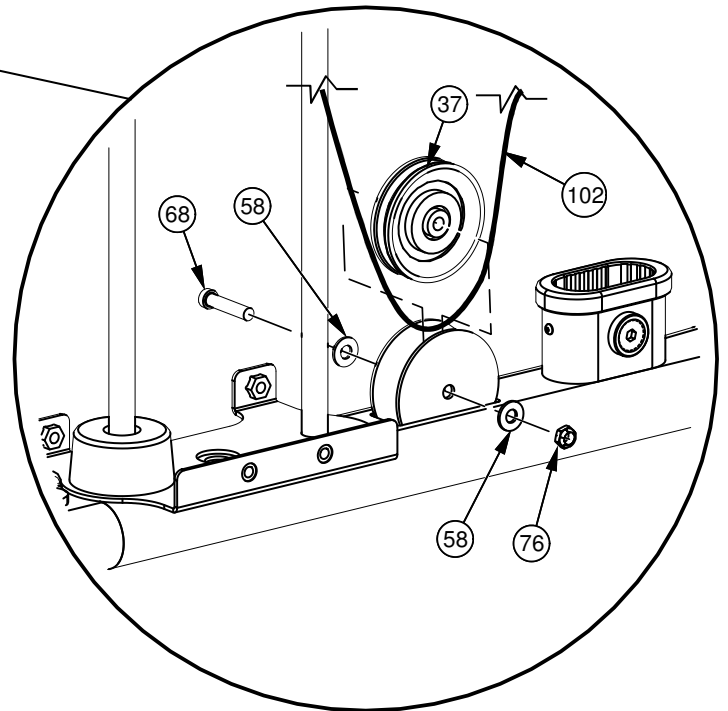

# OWNER'S MANUAL

**NOTE:**

- WRENCH TIGHTEN HARDWARE
- INSTALL **CABLE** AND PULLEYS AT THE SAME TIME.
- REPEAT STEPS FOR OPPOSITE SIDE OF HD-3000
- SOME PARTS MAY HAVE BEEN REMOVED FOR CLARITY.

## FRAME ASSEMBLY

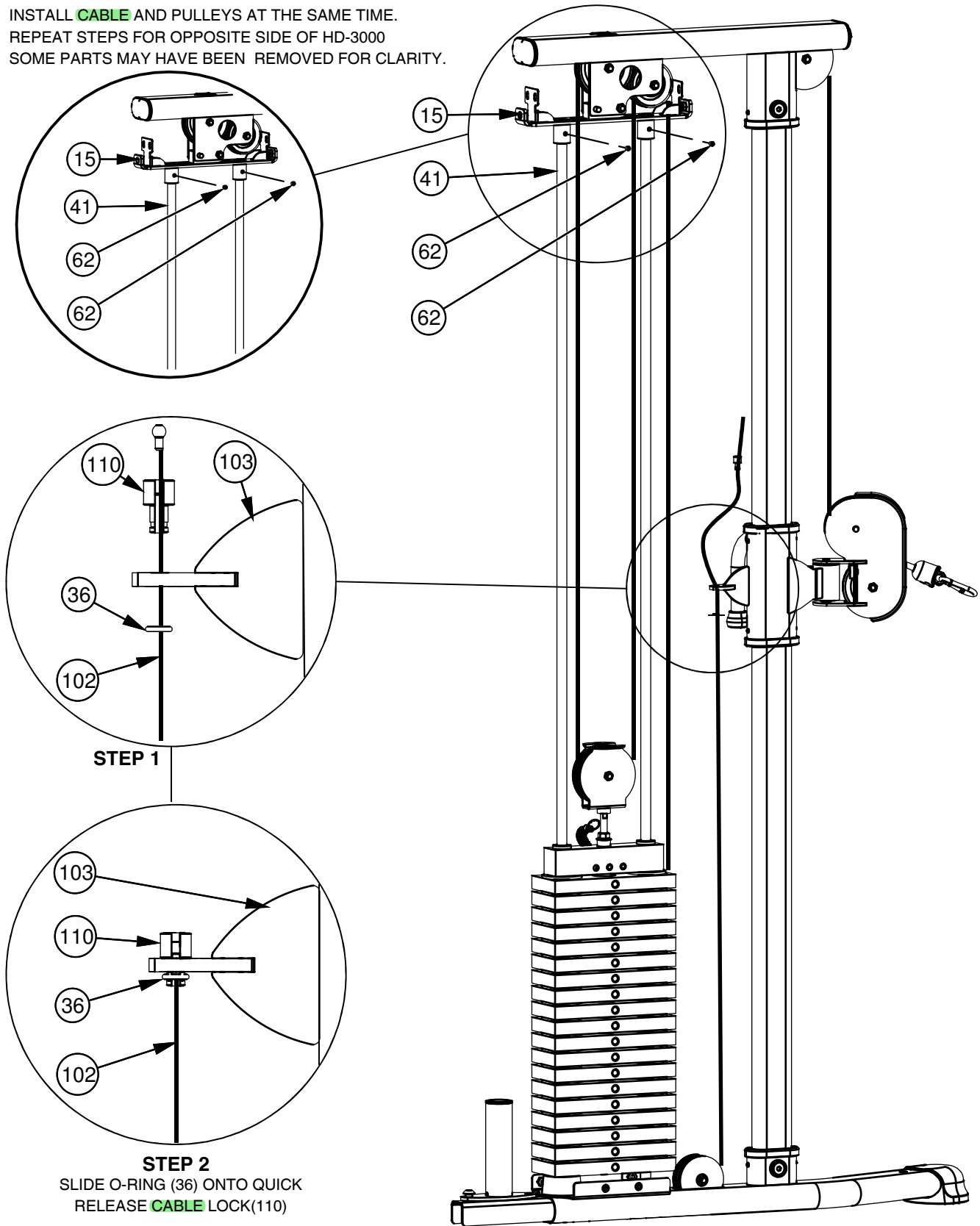

# OWNER'S MANUAL

## FRAME ASSEMBLY

NOTE:

- WRENCH TIGHTEN HARDWARE
- REPEAT STEPS FOR OPPOSITE SIDE
- SOME PARTS MAY HAVE BEEN REMOVED FOR CLARITY.

ROUTE **CABLE**  
THROUGH TUBE

ROUTE **CABLE**  
THROUGH HOLE

ROUTE **CABLE**  
THROUGH HOLE

ROUTE **CABLE**  
THROUGH HOLE

ADJUST **CABLE**,  
SO **CABLE** END REMAINS  
HANGING LOOSELY.

JAM  
NUT

(21)

JAM  
NUT

LOOSEN JAM NUTS AND THREAD PULLEY MOUNT(21) IN/OUT  
TO GIVE THE **CABLE** PROPER TENSION. RE-TIGHTEN JAM  
NUTS.

**WARNING** – PULLEY MOUNT BOLT(21) MUST BE THREADED  
A MINIMUM OF 3/8" INTO THE WEIGHT STEM(24) WITH  
JAM NUTS TIGHTENED SECURELY TO ENSURE PROPER  
CONNECTION.



# OWNER'S MANUAL

## FRAME ASSEMBLY

NOTE:

- WRENCH TIGHTEN HARDWARE
- WRENCH TIGHTEN ALL PREVIOUSLY HAND TIGHTENED HARDWARE
- SOME PARTS MAY HAVE BEEN REMOVED FOR CLARITY

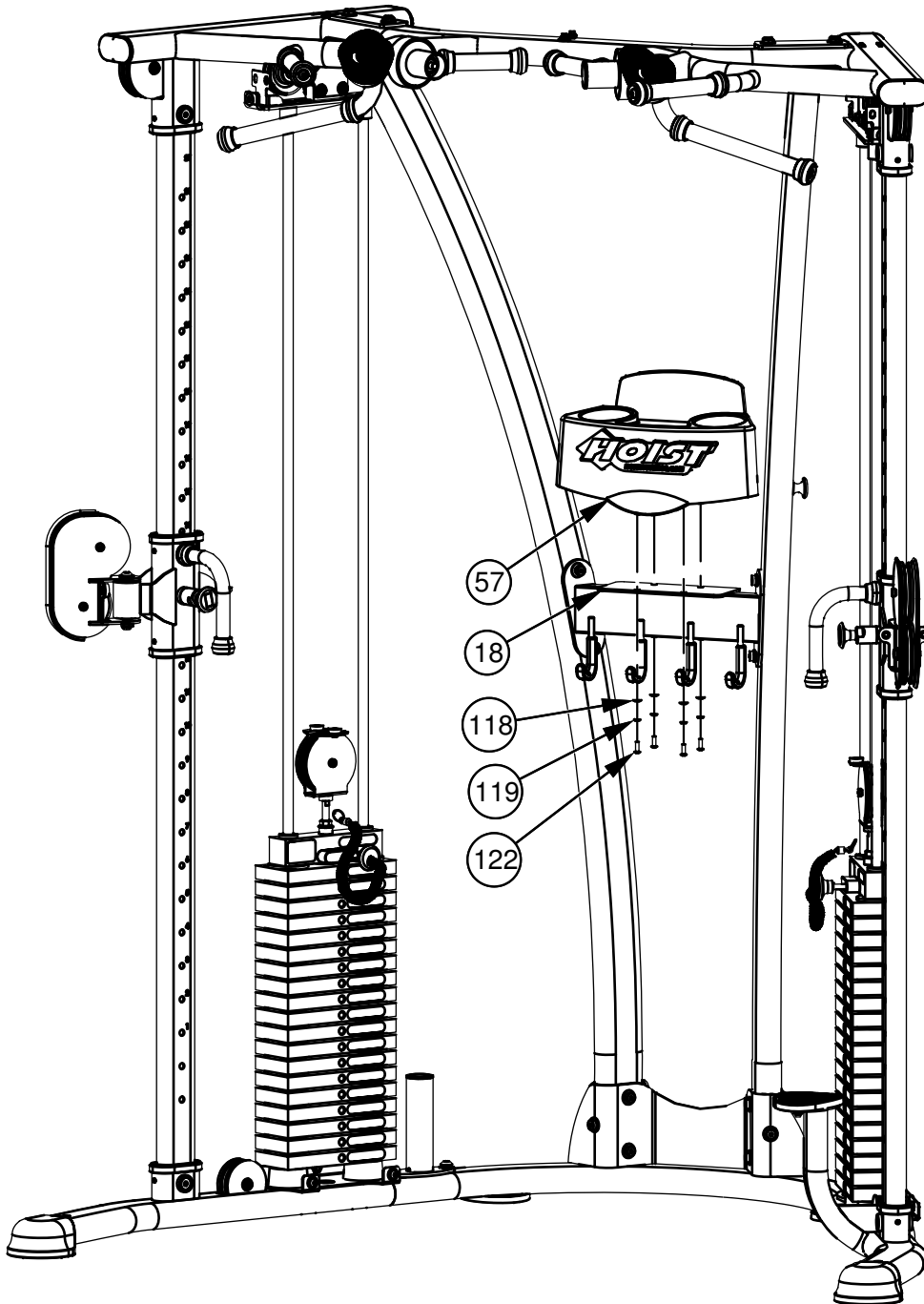

### \*IMPORTANT\*

TAKE TIME TO ASSURE THAT YOUR UNIT IS ASSEMBLED SQUARE AND PERPENDICULAR. USE A LEVEL TO CHECK THAT THE GUIDE RODS ARE PERPENDICULAR IN BOTH DIRECTIONS. IF THEY ARE NOT PERPENDICULAR IN BOTH DIRECTIONS, IT WILL BE NECESSARY TO LOOSEN SOME FRAME HARDWARE TO REALIGN THE FRAME AND RETIGHTEN BOLTS.

# OWNER'S MANUAL

## FRAME ASSEMBLY

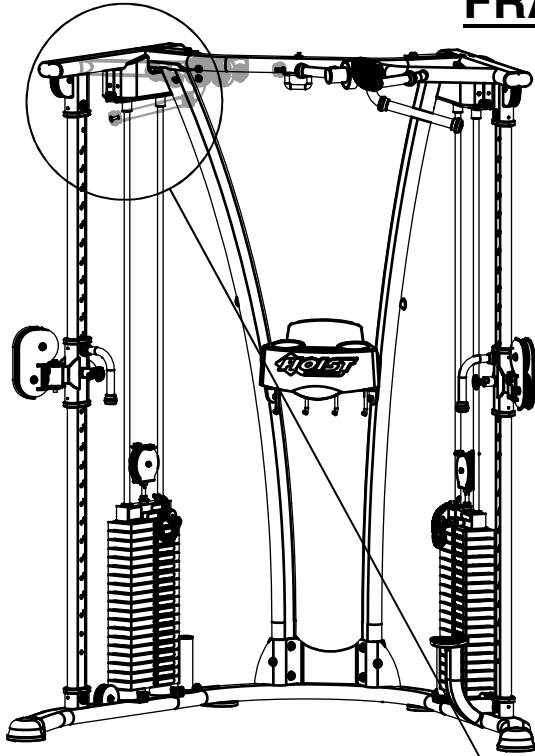

NOTE:

- HAND TIGHTEN HARDWARE
- REPEAT STEPS FOR OPPOSITE SIDE OF HD-3000
- SOME PARTS MAY HAVE BEEN REMOVED FOR CLARITY.

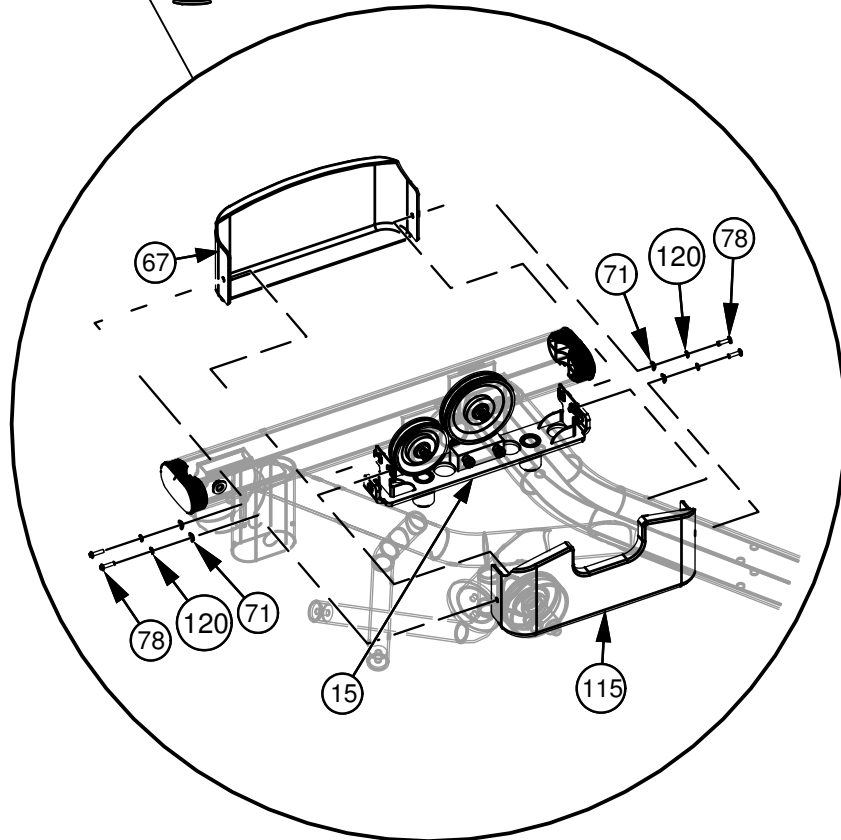

# OWNER'S MANUAL

**NOTE:**

- WRENCH TIGHTEN HARDWARE
- REPEAT FOR OPPOSITE SIDE
- SOME PARTS MAY HAVE BEEN REMOVED FOR CLARITY.
- WRENCH TIGHTEN ALL PREVIOUSLY HAND TIGHTENED HARDWARE

## FRAME ASSEMBLY

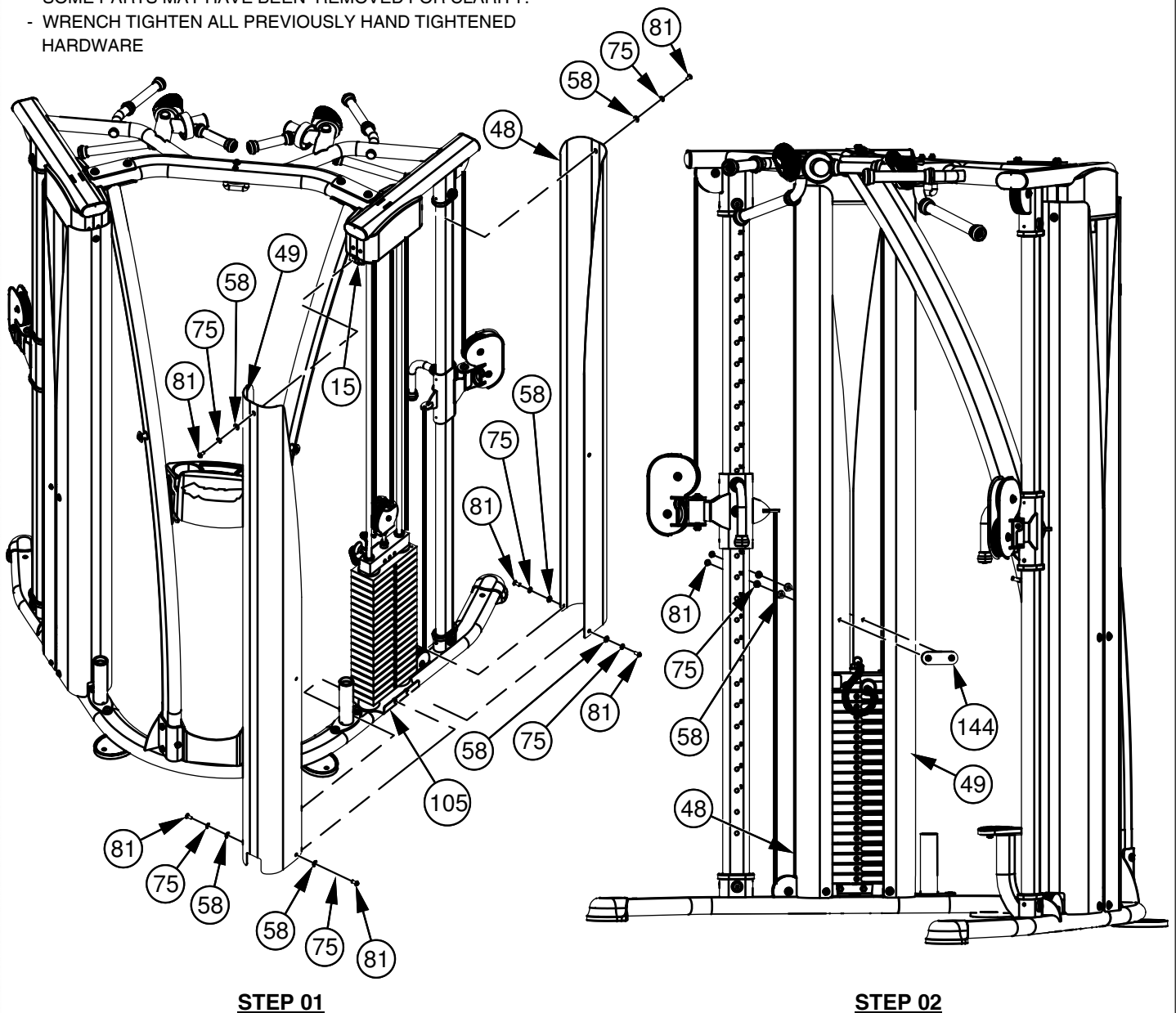

### \*IMPORTANT\*

NOW THAT THE HD-3000 IS COMPLETELY ASSEMBLED, TAKE TIME TO ASSURE THAT YOUR UNIT IS ASSEMBLED SQUARE AND PERPENDICULAR. USE A LEVEL TO CHECK THAT THE GUIDE RODS ARE PERPENDICULAR IN BOTH DIRECTIONS. IF THEY ARE NOT PERPENDICULAR IN BOTH DIRECTIONS, IT WILL BE NECESSARY TO LOOSEN SOME FRAME HARDWARE TO RE-ALIGN THE FRAME AND RETIGHTEN BOLTS.

# OWNER'S MANUAL

## PRE-ASSEMBLY

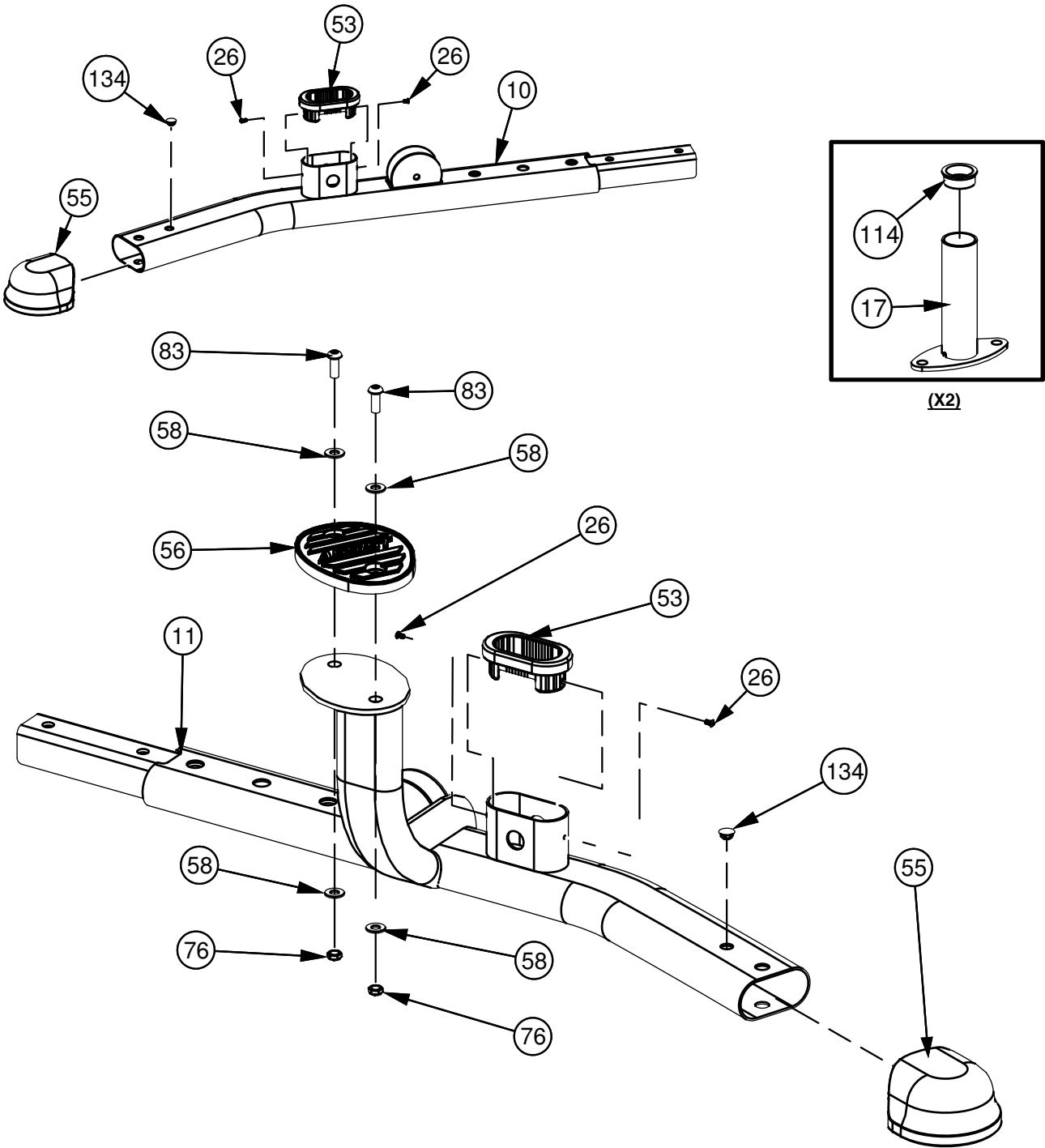

# OWNER'S MANUAL

## PRE-ASSEMBLY CONTINUED

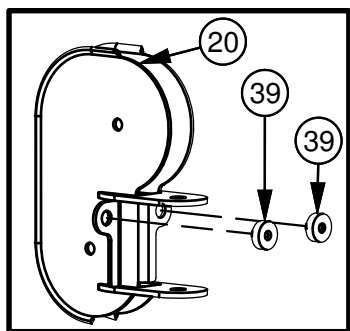

(X2)

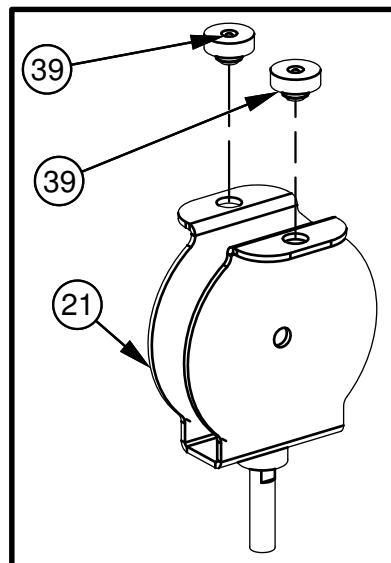

(X2)

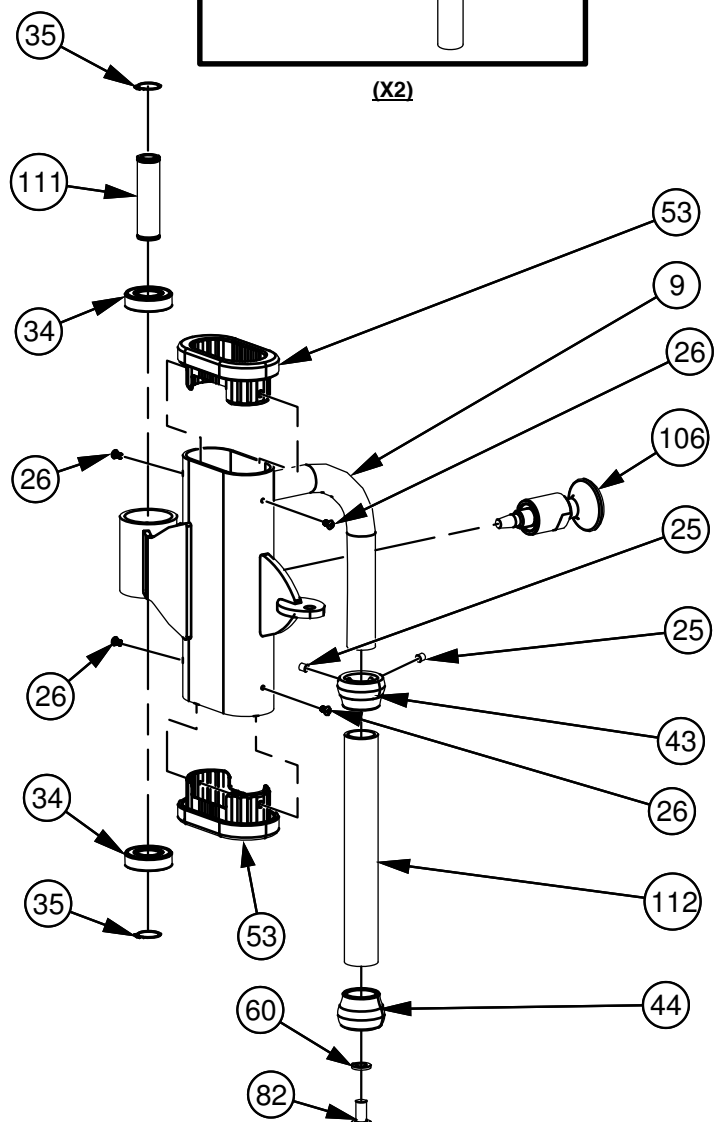
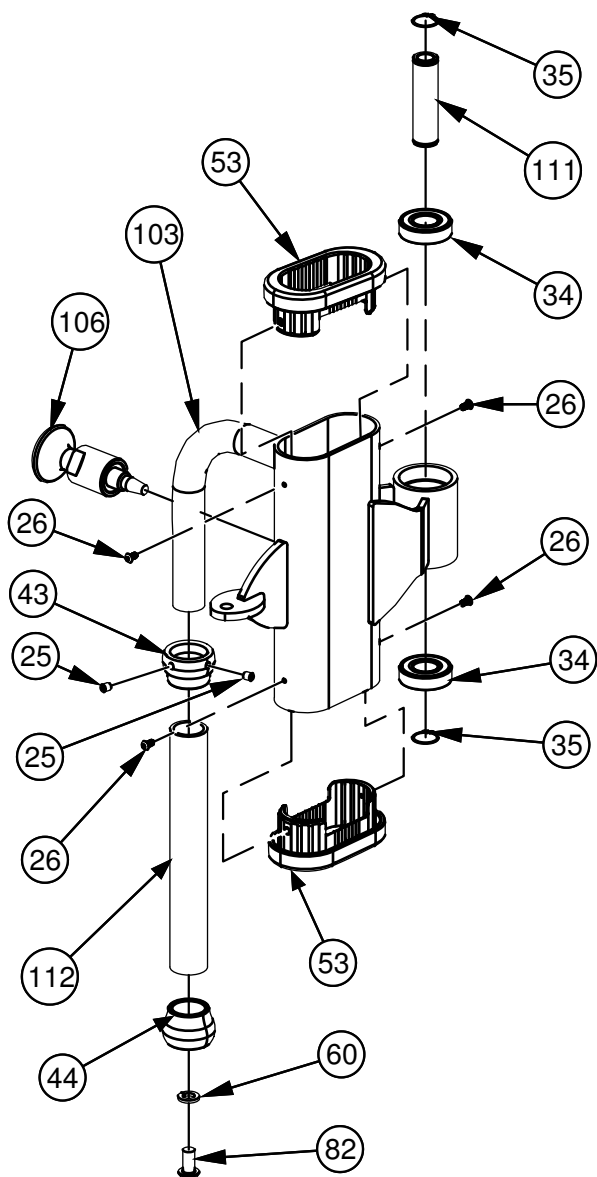

# OWNER'S MANUAL

## PRE-ASSEMBLY CONTINUED

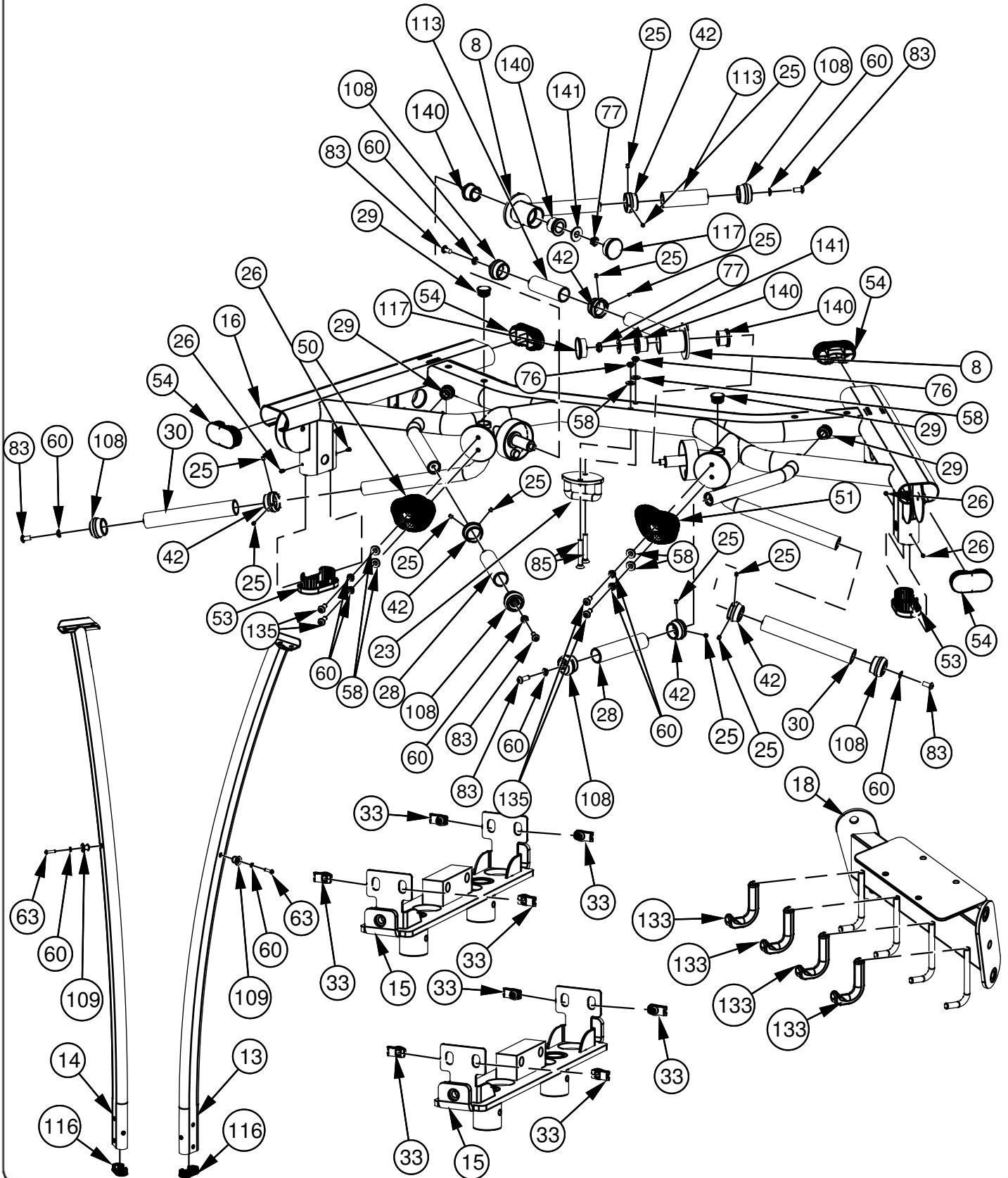

# OWNER'S MANUAL

## DECAL PLACEMENT

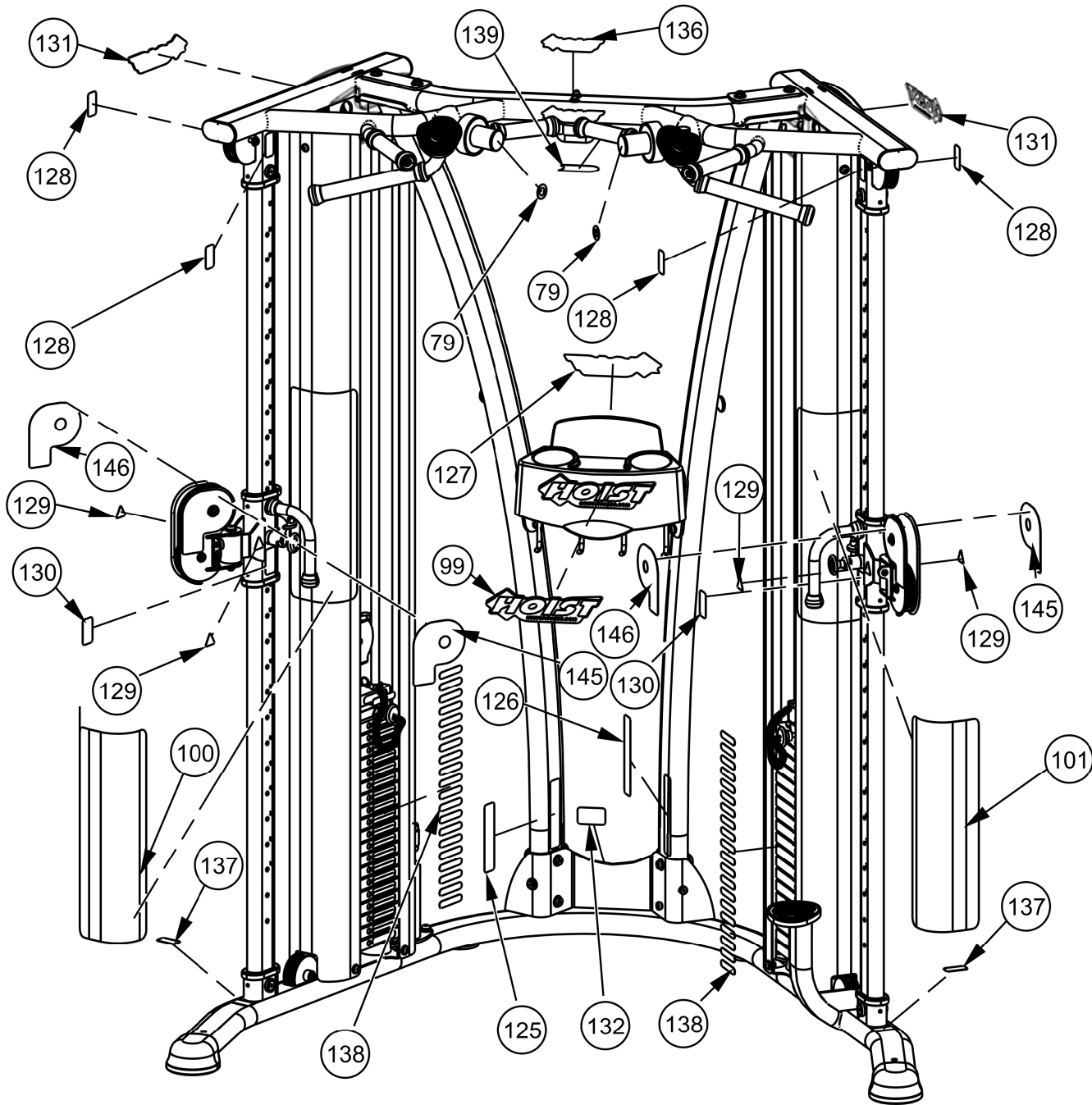

# OWNER'S MANUAL

## ACCESSORIES

NOTE:  
- SOME PARTS MAY HAVE BEEN REMOVED FOR CLARITY.

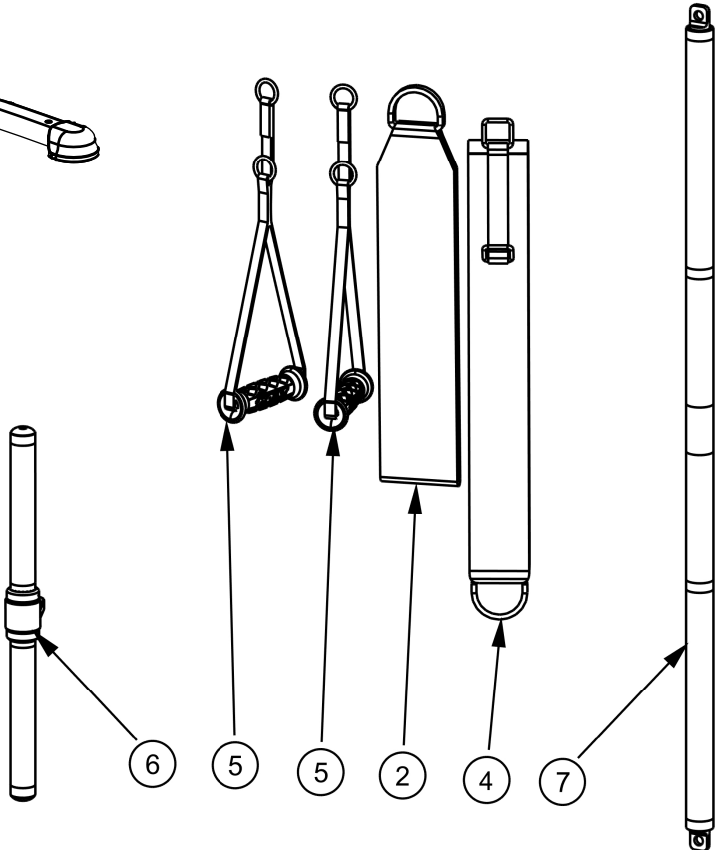
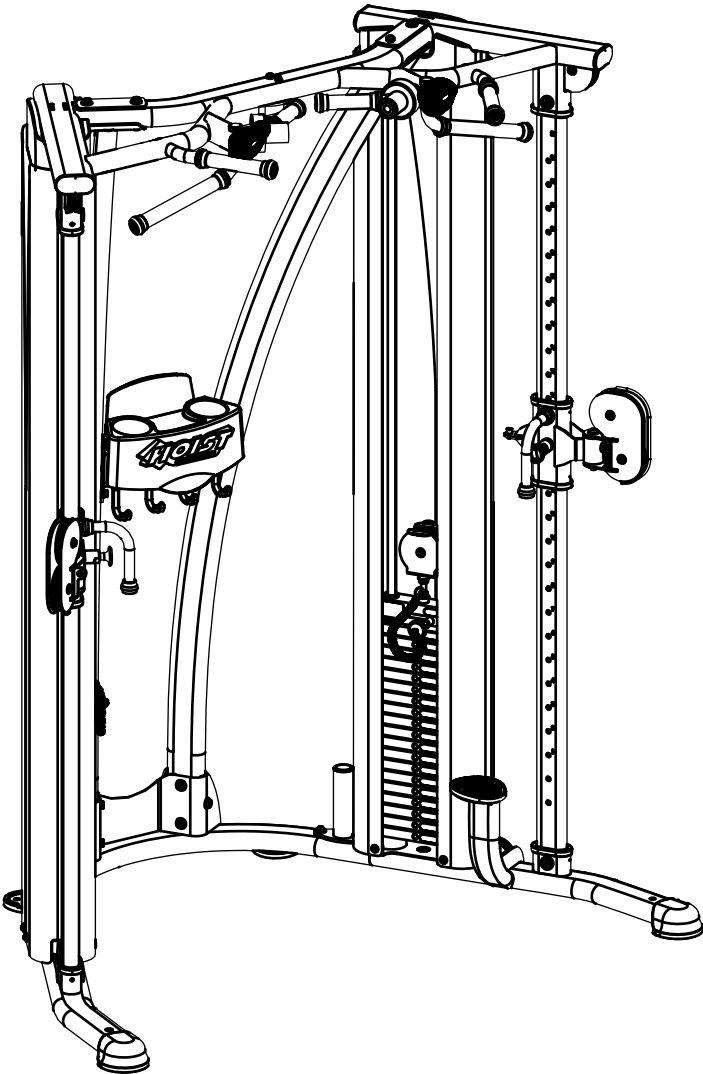



# OWNER'S MANUAL

## BOLTING TO THE FLOOR

NOTE:

- REMOVE PLUG(134) BEFORE INSERTING BOLT
- SOME PARTS MAY HAVE BEEN REMOVED FOR CLARITY.

**IMPORTANT**  
THIS HOLE IS ONLY  
USED TO BOLT THE  
UNIT TO THE FLOOR

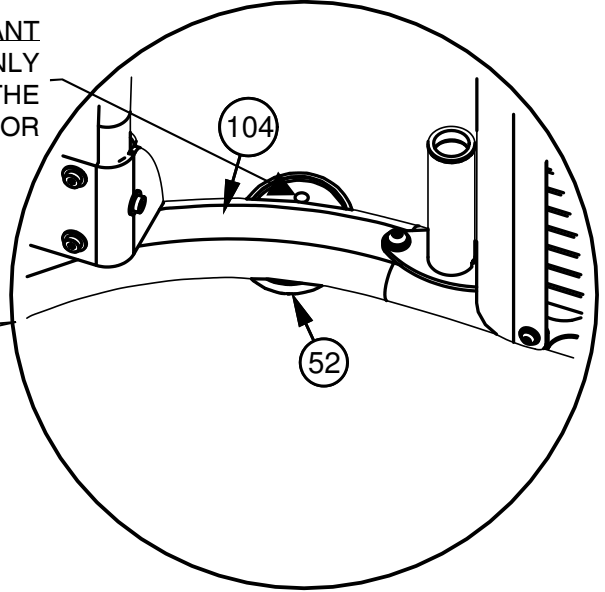

**IMPORTANT**  
THIS HOLE IS ONLY USED TO  
BOLT THE UNIT TO THE FLOOR

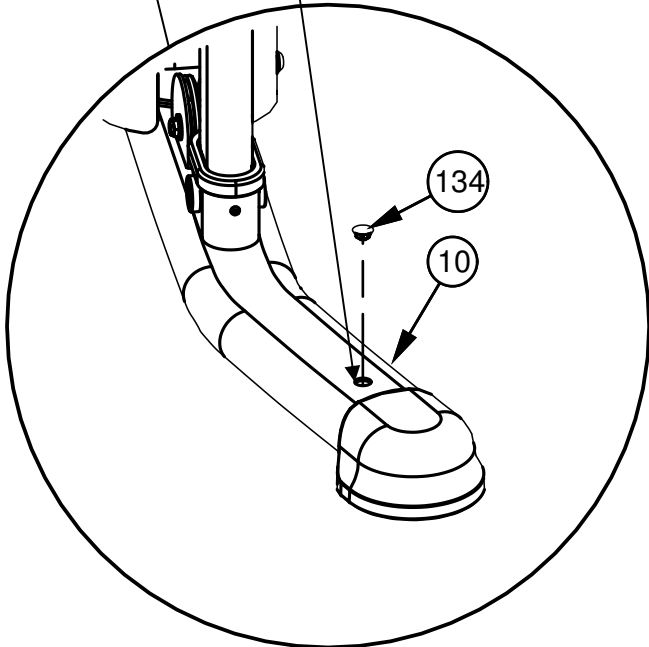

**IMPORTANT**  
THIS HOLE IS ONLY USED  
TO BOLT THE UNIT TO  
THE FLOOR

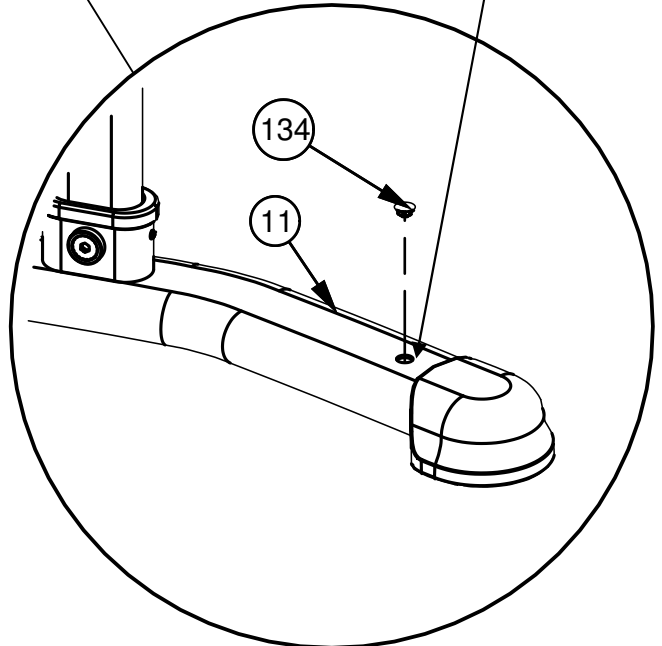

# OWNER'S MANUAL

## DECAL REFERENCE



SERIAL # DECAL



021-0003230

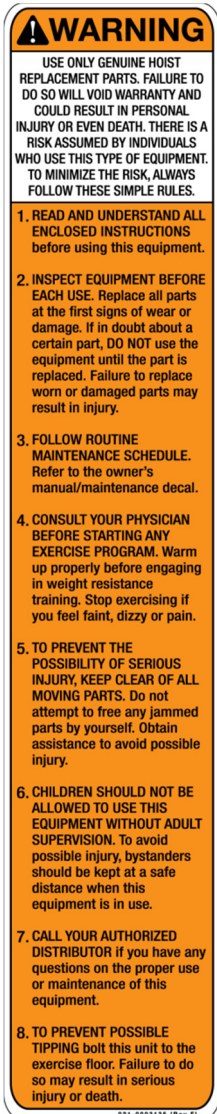

021-0003135

COMMERCIAL MAINTENANCE	NOTICE			
	Daily	Weekly	Monthly	Yearly
Inspect; Links, Pull Pins, Snap Locks, Swivels, Weight Stack Pins	X			
Clean; Upholstery	X			
Inspect; Cables or Belts and their tension	X			
Inspect; Accessory Bars and Handles		X		
Inspect; All Decals		X		
Inspect; All nuts and Bolts Tighten if Needed.		X		
Inspect; Anti-Skid Surfaces		X		
Clean & Lubricate; Guide Rods with a Teflon (PTFE) based lubricant (Superlube)			X	
Lubricate; Seat Sleeves, Turcite Bushings, Linear Bearing			X	
Clean & Wax; All Glossy Finishes				X
Repack with Grease Linear Bearings				X
Replace; Cables, Belts and Connecting Parts.				X

021-0003008 (Rev. 11)

021-0003008



021-0018022-1



021-0003973



021-0003221

# OWNER'S MANUAL

## DECAL REFERENCE

10 LBS / 5 KGS	90 LBS / 41 KGS	170 LBS / 77 KGS
20 LBS / 9 KGS	100 LBS / 45 KGS	180 LBS / 82 KGS
30 LBS / 14 KGS	110 LBS / 50 KGS	190 LBS / 86 KGS
40 LBS / 18 KGS	120 LBS / 54 KGS	200 LBS / 91 KGS
50 LBS / 23 KGS	130 LBS / 59 KGS	
60 LBS / 27 KGS	140 LBS / 64 KGS	
70 LBS / 32 KGS	150 LBS / 68 KGS	
80 LBS / 36 KGS	160 LBS / 73 KGS	

021-0003965

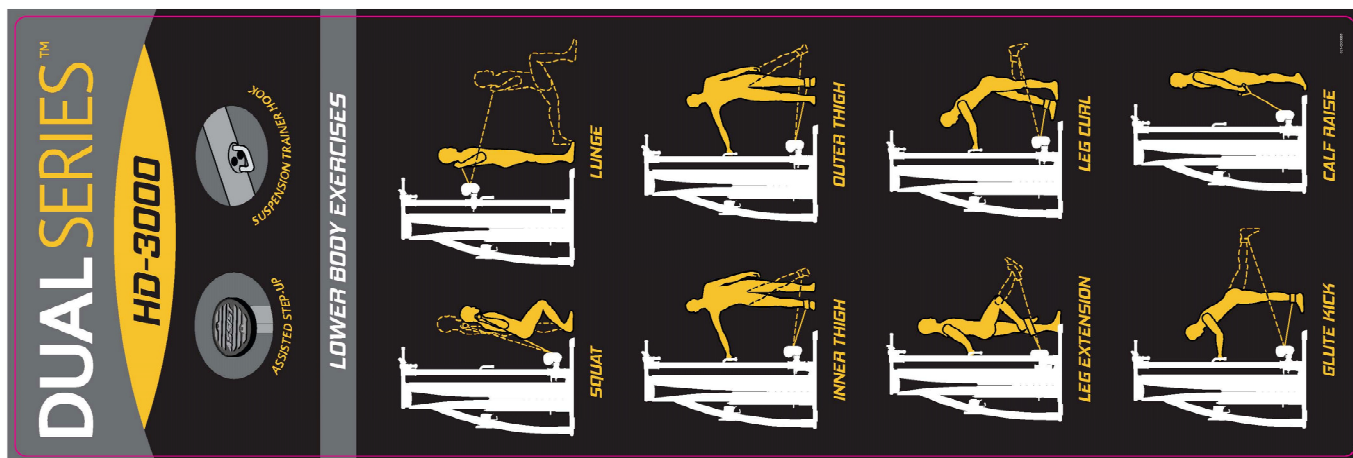

021-0003986

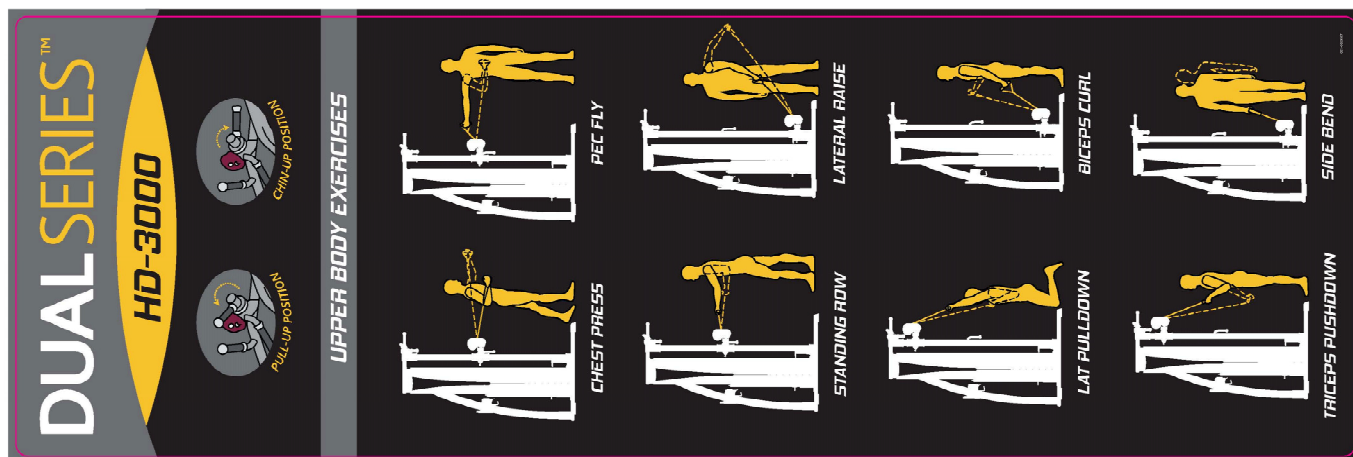

021-0003987

# OWNER'S MANUAL

## DECAL REFERENCE



021-0003978



021-0003341

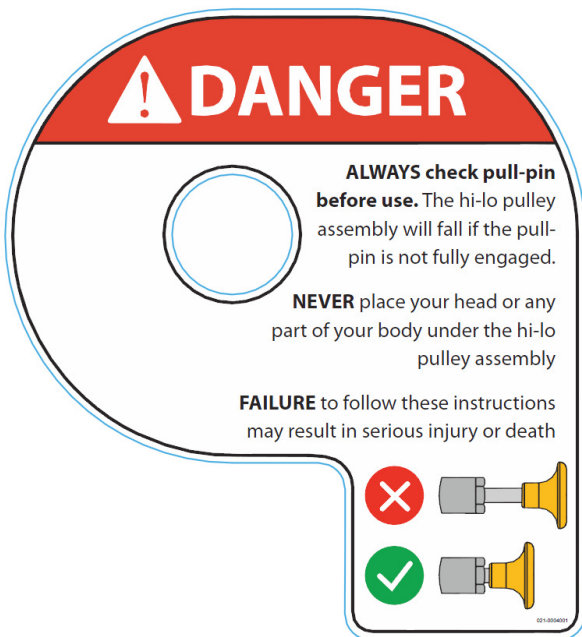

021-0004001

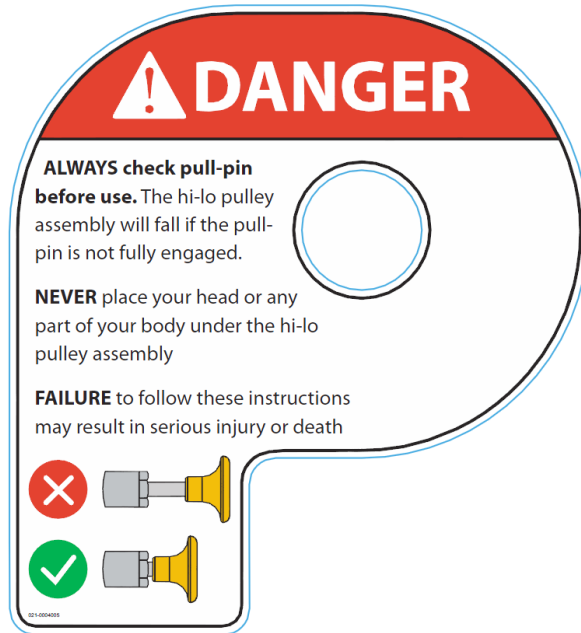

021-0004005



021-0003512

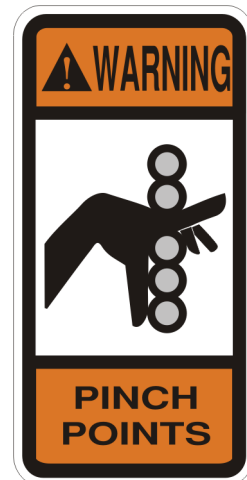

021-0003322

# OWNER'S MANUAL

## PART LIST

NOTE: SOME OF THESE PARTS MAY COME PRE-INSTALLED

ITEM NO.	PART NUMBER	DESCRIPTION	QTY
2	020-0003004	CHIN ASSIST 4" WIDE	1
4	026-01X6020	FLEECE KNEE STRAP WITH (1) D-RING & 2 SQ. RINGS ASSEMBLY	1
5	026-01X1632	STRAP HANDLE WITH (2) O-RINGS (LOWER)	2
6	026-01X1118	ALUMINUM CURL BAR ASSEMBLY	1
7	026-01X1121	ALUMINUM STRAIGHT BAR ASSEMBLY	1
8	026-01X3728	45 DEG. SWIVEL HANDLE ASSEMBLY	2
9	026-01X3988	SWIVEL PULLEY ADJUSTER R	1
10	026-01X6774	BASE FRAME-LFT	1
11	026-01X6775	BASE FRAME-RT	1
12	026-01X6776	ADJUSTER COLUMN	2
13	026-01X6777	SIDE UPRIGHT-LEFT	1
14	026-01X6778	SIDE UPRIGHT-RIGHT	1
15	026-01X6779	GUIDE ROD TOP BRACKET	2
16	026-01X6780	CHIN-UP STATION FRAME	1
17	026-01X6781	ACCESSORY BAR HOLDER	2
18	026-01X6782	MIDDLE CROSS-MEMBER	1
20	026-01X7013	SWIVEL PULLEY HOUSING	2
21	026-01X5528	ADJUSTABLE PULLEY MOUNT	2
23	026-01X7116	STRAP MOUNT	1
24	WS#22 + 50 LBS UPGRADE	200 LBS. STACK (8.25 LBS. TOP PLATE W/ 20 HOLE STEM	2
25	011-0711001	SET SCREW: 1/4"-28 X .25" LG. (Ni)	16
26	011-0701120	M4 BHB x 8mm(Ni)	16
27	012-0102015	1/2"-20 FLANGED NUT (WZ)-LH	4
28	026-01PL0235-18	GRIP: OPEN ENDED $\phi$ 1.25" X 6.00" LG.	2
29	016-0201038	$\phi$ 1.25" ENDCAP (DOMED)	4
30	026-01PL0235-38	GRIP: OPEN ENDED $\phi$ 1.43" X 9.13" LG.	2
33	012-0609007	CLIP ON NUT, 10-32	8
34	014-0012015	BEARING: FLANGELESS $\phi$ 1.65" O.D. X $\phi$ .79" I.D. X .47" WIDE	4
35	014-0012017	SNAP RING - 20mm EXTERNAL	4
36	015-0003006	RUBBER O-RING: 5/16" ID X 1/2" OD	2
37	018-0001002	CABLE PULLEY: $\phi$ 3.50"	4
38	018-0001003	CABLE PULLEY: $\phi$ 4.50"	10
39	019-0001001	PLUG BUMPER	8
40	019-0001005	WEIGHT STACK BUMPER	4
41	026-01G0225	GUIDE ROD: $\phi$ .75" CRS X 83.13" LG.	4
42	026-01M0933	ALUMINUM RING: $\phi$ 1.25" ID	6
43	026-01M0936	ALUMINIUM RING: $\phi$ 1.00" I.D.	2
44	026-01M0937	END CAP: ALUMINUM $\phi$ 1.0" I.D.	2



# OWNER'S MANUAL

## PART LIST CONTINUED

NOTE: SOME OF THESE PARTS MAY COME PRE-INSTALLED

ITEM NO.	PART NUMBER	DESCRIPTION	QTY
45	026-01M3451	FLANGED SPACER	8
46	026-01P4762	PLATE	2
48	026-01P4766	HD-3000 SHIELD-1	2
49	026-01P4767	HD-3000 SHIELD-2	2
50	026-01PL2444	CLIMB HOLD, LEFT	1
51	026-01PL2445	CLIMB HOLD, RIGHT	1
52	026-01PL2122	OVAL-SHAPED RUBBER FOOT	2
53	026-01PL2564	GLIDE SLEEVE	8
54	026-01PL2566	50 X 100 OVAL DOMED END CAP	4
55	026-01PL2641	FOOTCAP, 1.97" X 3.94" F.O.	2
56	026-01PL2813	5 X 6.5" OVAL FOOT-PLATE	1
57	026-01PL2815	CENTER CONSOLE	1
58	013-1002007	3/8" X 22mm FLAT WASHER (Ni)	63
59	013-1002006	1/2" X 27mm SAE FLAT WASHER (Ni)	32
60	013-1006003	3/8" SPLIT LOCK WASHER (Ni)	14
61	013-1006004	1/2" SPLIT LOCK WASHER (Ni)	8
62	011-0311009	5/16"-18UNC X .31" SET SCREW (BZ)	4
63	011-0701125	3/8"-16UNC X 1.50" BHCS (Ni) W/ DRI-LOC PATCH	2
65	011-0701058	1/2"-13UNC X 4.00" BHCS (Ni)	2
67	026-01PL2816	OUTER PULLEY COVER	2
68	011-0116145	3/8"-16UNC X 1.75" LOW HEAD SHCS (Ni)	10
69	011-0116146	3/8"-16UNC X 2.00" LOW HEAD SHCS (Ni)	8
71	013-1002011	#10 FLAT WASHER (Ni)	8
72	011-0116108	1/2"-13UNC X 1.25" LOW HEAD SHCS (Ni)	4
75	013-1010002	3/8" INTERNAL LOCK WASHER (Ni)	16
76	012-0504005	3/8"-16 UNC THIN NYLOCK NUT (Ni)	22
77	012-0504002	1/2"-13 UNC THIN NYLOCK NUT (Ni)	14
78	011-0701113	#10-32UNC x .75 BHCS (Ni)	8
79	021-0003427	DECAL ADJUST	2
81	011-0701019	3/8"-16UNC X .75" BHCS (Ni)	16
82	011-0701089	3/8"-16UNC X .75" BHCS (Ni) W/ DRI-LOC PATCH	2
83	011-0701020	3/8"-16UNC X 1.00" BHCS (Ni)	8
85	011-0702010	3/8"-16UNC X 2.75" FHCS (Ni)	2
91	011-0702025	1/2"-13UNC X 1.25" FHS (Ni)	8
99	021-0003973	DECAL HOISTFITNESS.COM LOGO CURVED	1
100	021-0003987	HD-3000 PLACARD LEFT	1
101	021-0003986	HD-3000 PLACARD RIGHT	1
102	010-01C0704	CABLE 314 11/16" LG.	2

# OWNER'S MANUAL

## PART LIST CONTINUED

NOTE: SOME OF THESE PARTS MAY COME PRE-INSTALLED

ITEM NO.	PART NUMBER	DESCRIPTION	QTY
103	026-01X3987	SWIVEL PULLEY ADJUSTER L	1
104	026-01X6773	REAR BASE FRAME	1
105	026-01X6784	LOWER SHIELD MOUNT	2
106	026-01X6785	PULLPIN ASSEMBLY (TAPERED)	2
107	026-01F0277	FLNG-F, 2.5" X 7.0"	2
108	026-01M0932	ALUMINIUM CAP: Ø1.25" ID	6
109	026-01M1013	Ø 1.50" TOWEL HANGER	2
110	026-01M2562A	QUICK RELEASE CABLE LOCK - 1/8" CABLE	2
111	026-01M2661	SHAFT Ø .787" OD X Ø .52" ID X 2.94" LG.	2
112	026-01PL0206-01	GRIP Ø 1.00" X 8.25" LG.	2
113	026-01PL0235-12	GRIP OPEN END Ø 1.43" X 4.25" LG.	2
114	026-01PL0371	DELTRIN BUSHING	2
115	026-01PL2817	INNER PULLEY COVER	2
116	026-01PL2818	CAP 1.97" X 3.94"	2
117	016-0201022	END CAP Ø 2.00" (BLACK)	2
118	013-1002008	1/4" X 16mm SAE FLAT WASHER (Ni)	4
119	013-1006001	1/4" SPLIT LOCK WASHER (Ni)	4
120	013-1010007	#10 INTERNAL LOCK WASHER (Ni)	8
121	011-0701049	1/2"-13UNC X 1.50" BHCS (Ni)	4
122	011-0701076	1/4"-20UNC X .75" BHCS (Ni)	4
123	011-0116115	1/2"-13UNC X 3.00" LOW HEAD SHCS (Ni)	8
124	011-0116123	1/2"-13UNC X 5.00" LOW HEAD SHCS (Ni)	2
125	021-0003008	DECAL COMMERCIAL MAINTENANCE 1.50 X 6.69	1
126	021-0003135	DECAL WARNING 1.50" X 7.75"	1
127	021-0003221	DECAL HOIST 2.50" X 9.13"	1
128	021-0003322	DECAL PINCH POINT 1.25" X 2.31" (VERTICAL)	4
129	021-0003512	DECAL PINCH POINT 1.18" X 1.35" (TRIANGLE)	4
130	021-0004138	DECAL, PULLEY WARNING	2
131	021-0018022-1	DECAL HOISTFITNESS.COM LOGO	2
132	SERIAL # DECAL	DECAL SERIAL # 1.63" X 2.63"	1
133	026-01PL2821	ACCESSORY HOOK COVER	4
134	016-0203005-G	1/2" PLUG	2
135	011-0701084	3/8"-16UNC X 1.25" BHCS (Ni) W/ DRI-LOC PATCH	4
136	021-0003230	DECAL HOIST 1.625" X 6.0613"	1
137	021-0003341	DECAL PINCH POINT 1.07" X 2.13" (HORIZONTAL)	2
138	021-0003965	DECAL: WEIGHT STACK 22 (10-200 LBS.)	2
139	021-0003978	DECAL HOOK WARNING	1

# OWNER'S MANUAL

## **PART LIST CONTINUED**

NOTE: SOME OF THESE PARTS MAY COME PRE-INSTALLED

ITEM NO.	PART NUMBER	DESCRIPTION	QTY
140	014-0101005	BUSHING: OILITE FLANGED Ø1.38" O.D. X Ø1.00" I.D. X .81" LG.	4
141	013-1002004	1/2" X 34mm USS FLAT WASHER (Ni)	2
142	002-0001013	1cc of Synthetic Multi-Purpose Grease (PTFE)	4
143	002-0001036	TOUCH-UP PAINT - BOTTLE: 1oz. - COLOR: PLATINUM	1
144	026-01X6794	SHIELD TIE	2
145	021-0004005	HI-LO PULLEY WARNING DECAL	2
146	021-0004001	HI-LO PULLEY WARNING DECAL	2



# OWNER'S MANUAL

## ABBREVIATIONS

BZ = Black Zinc  
Ni = Nickel Plated  
SS = Stainless Steel  
WZ = White Zinc

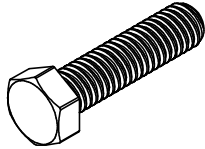

HHB = Hex Head Bolt

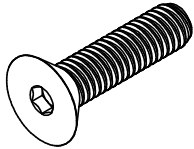

FHCS = Flat Head Cap Screw

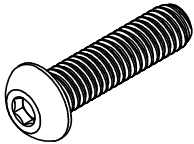

BHCS = Button Head Cap Screw

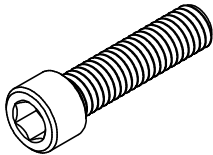

SHCS = Socket Head Cap Screw

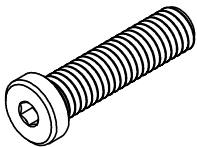

Low Head SHCS = Low Head Socket  
Head Cap Screw

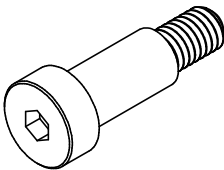

SHSS = Socket Head Shoulder Screw

# OWNER'S MANUAL

## BOLT SIZING CHART

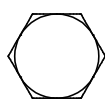

**1/4" HHB**  
RECOMMENDED  
TORQUE RANGE:  
6-8 ft-lbs

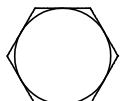

**5/16" HHB**  
RECOMMENDED  
TORQUE RANGE:  
14-17 ft-lbs

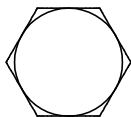

**3/8" HHB**  
RECOMMENDED  
TORQUE RANGE:  
24-30 ft-lbs

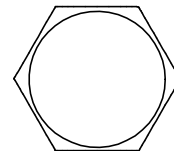

**1/2" HHB**  
RECOMMENDED  
TORQUE RANGE:  
60-75 ft-lbs



**1/4" BHCS**  
RECOMMENDED  
TORQUE RANGE:  
5-7 ft-lbs

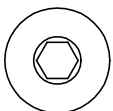

**5/16" BHCS**  
RECOMMENDED  
TORQUE RANGE:  
11-15 ft-lbs

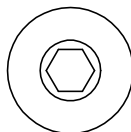

**3/8" BHCS**  
RECOMMENDED  
TORQUE RANGE:  
19-26 ft-lbs

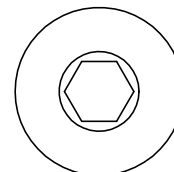

**1/2" BHCS**  
RECOMMENDED  
TORQUE RANGE:  
47-65 ft-lbs



**1/4" LOW HEAD SHCS**  
RECOMMENDED  
TORQUE RANGE:  
4-6 ft-lbs

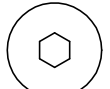

**5/16" LOW HEAD SHCS**  
RECOMMENDED  
TORQUE RANGE:  
9-12 ft-lbs

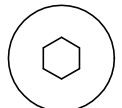

**3/8" LOW HEAD SHCS**  
RECOMMENDED  
TORQUE RANGE:  
18-23 ft-lbs

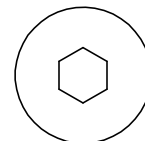

**1/2" LOW HEAD SHCS**  
RECOMMENDED  
TORQUE RANGE:  
40-50 ft-lbs



**1/4" SHCS**  
RECOMMENDED  
TORQUE RANGE:  
11-14 ft-lbs

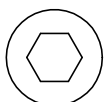

**5/16" SHCS**  
RECOMMENDED  
TORQUE RANGE:  
23-29 ft-lbs

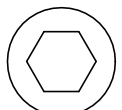

**3/8" SHCS**  
RECOMMENDED  
TORQUE RANGE:  
39-49 ft-lbs

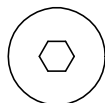
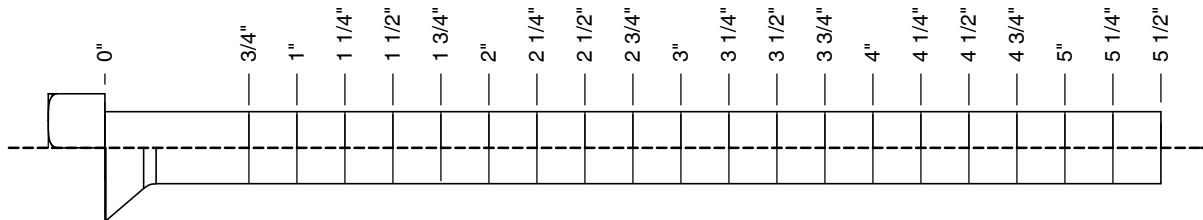

**1/4" FHCS**  
RECOMMENDED  
TORQUE RANGE:  
5-7 ft-lbs

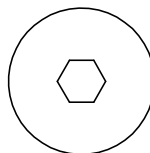

**3/8" FHCS**  
RECOMMENDED  
TORQUE RANGE:  
19-26 ft-lbs

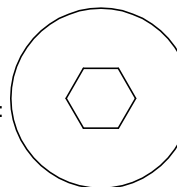

**1/2" FHCS**  
RECOMMENDED  
TORQUE RANGE:  
47-65 ft-lbs

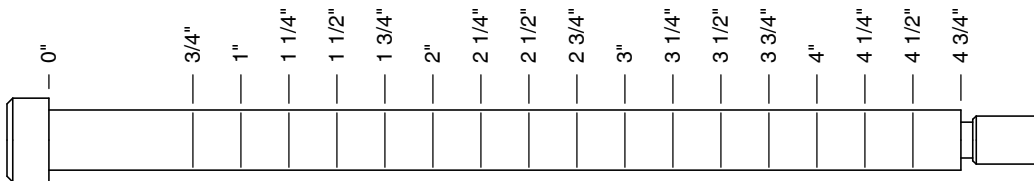

**1/4" SHSS**  
RECOMMENDED  
TORQUE RANGE:  
3-4 ft-lbs



**5/16" SHSS**  
RECOMMENDED  
TORQUE RANGE:  
8-10 ft-lbs

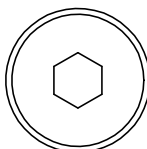

**3/8" SHSS**  
RECOMMENDED  
TORQUE RANGE:  
17-22 ft-lbs

# OWNER'S MANUAL

## WASHER SIZING CHART

013-0002003  
1/4"  
FLAT WASHER  
SMALL, SAE, 13mm

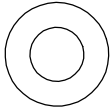

013-0102004  
5/16"  
FLAT WASHER  
LARGE, USS, 22mm

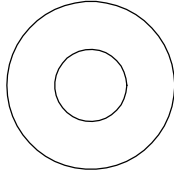

013-0002004  
3/8"  
FLAT WASHER  
SMALL, SAE, 21mm

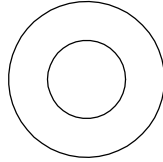

013-0402005  
3/8"  
FLAT WASHER  
LARGE, USS, 25mm

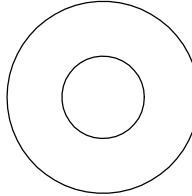

013-0102003  
1/2"  
FLAT WASHER  
SMALL, SAE, 27mm

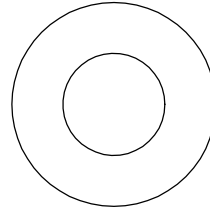

013-0102026  
1/2"  
FLAT WASHER  
LARGE, USS, 34mm

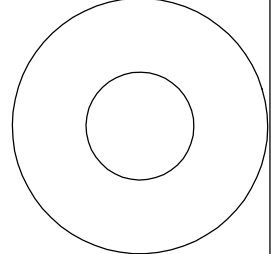

013-0102028  
3/8"  
CURVED WASHER

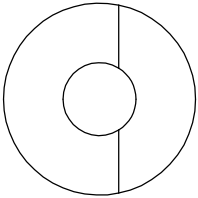

013-0402007  
3/8"  
FLAT WASHER  
22mm O.D.

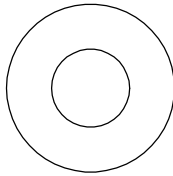

013-0102019  
1/4"  
LOCK WASHER



013-0102020  
3/8"  
LOCK WASHER

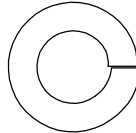

013-0102018  
1/2"  
LOCK WASHER

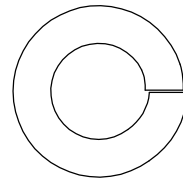

014-0018001  
1/2" LONG  
SPACER

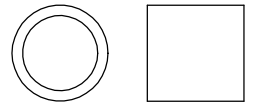

026-01M0238  
2" ALUMINUM  
FLATHEAD CAP

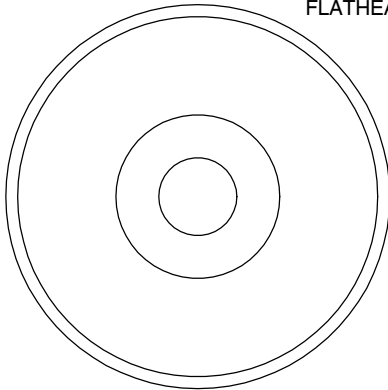

016-0009003  
1" SHIM WASHER

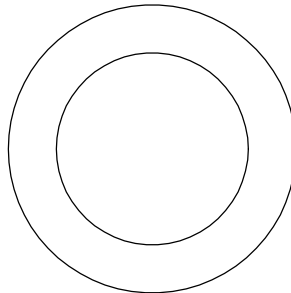

013-0003002  
3/8" FENDER WASHER

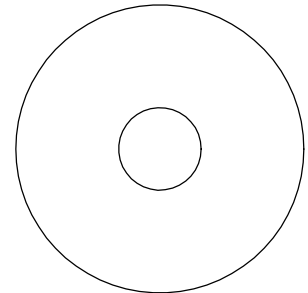

013-0003004  
1 1/16"  
FENDER WASHER

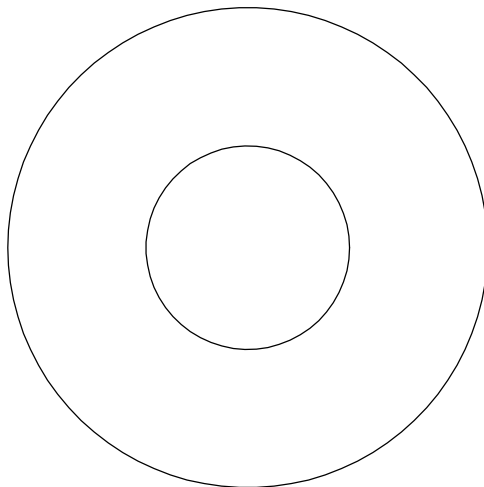

026-01PL151  
PLASTIC 1 1/16"  
FENDER WASHER

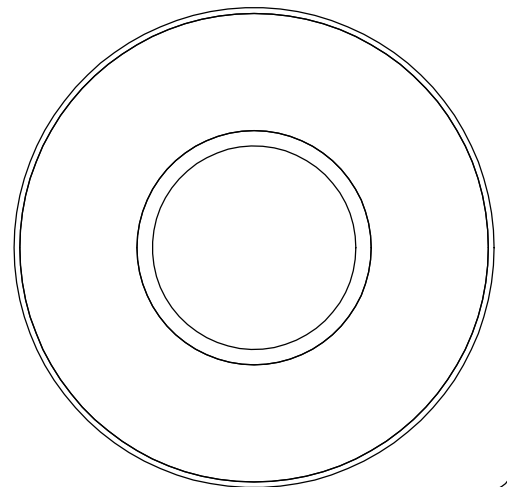

014-0018002  
1" LONG  
SPACER

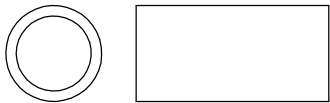

# OWNER'S MANUAL

## WASHER SIZING CHART (CONTINUED)

**026-01M0211**  
1/4" LONG  
FLANGED SPACER

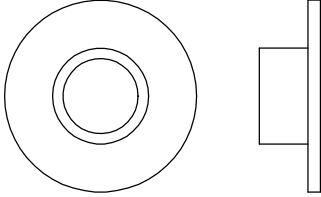

026-01M0198  
1/2" LONG  
FLANGED SPACER

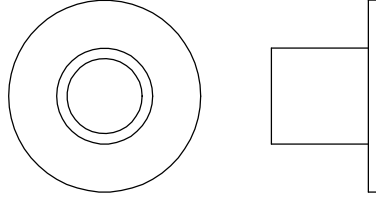

**026-01M0760**  
1/2" LONG HEAVY  
FLANGED SPACER

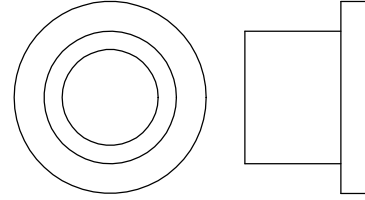

026-01M211T  
1/4" LONG HEAVY  
FLANGED SPACER

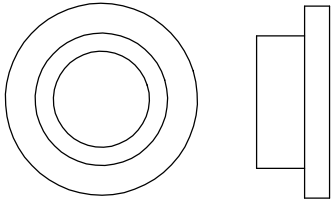

026-01M0532  
11/16" LONG HEAVY  
FLANGED SPACER

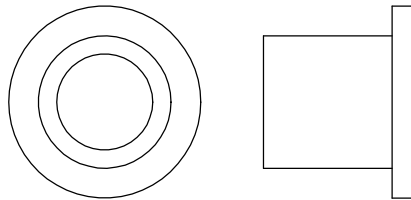

**026-01M0551**  
1" LONG HEAVY  
FLANGED SPACER

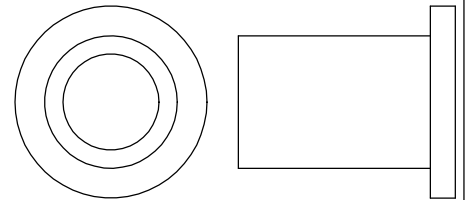

026-01M0788  
.81" LONG HEAVY  
FLANGED SPACER

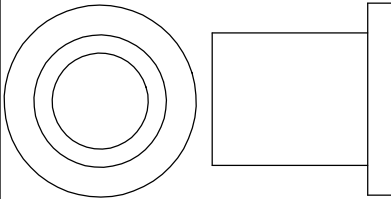

026-01M0780  
.65" LONG HEAVY  
FLANGED SPACER

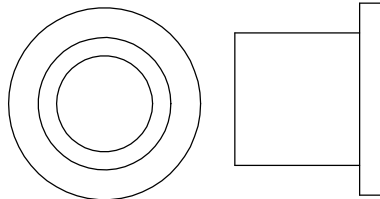

026-01M0761  
1 11/16" LONG HEAVY  
FLANGED SPACER

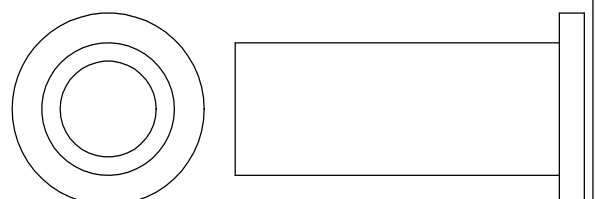

026-01M0789  
.44" LONG HEAVY  
FLANGED SPACER

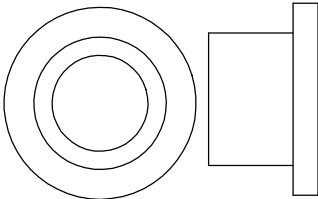

026-01M0762  
1 1/2" LONG HEAVY  
FLANGED SPACER

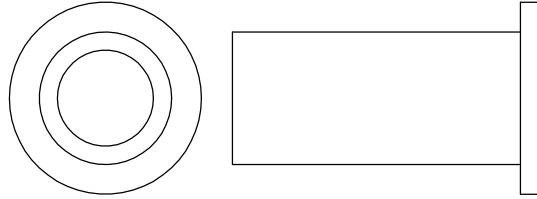

026-01M0768  
1 1/4" LONG HEAVY  
FLANGED SPACER

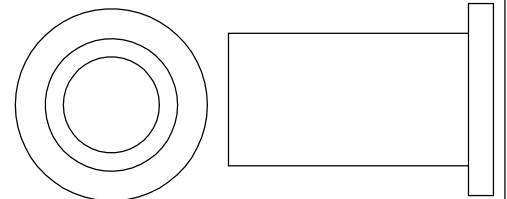

**026-01M0600**  
.625" LONG  
FLANGED SPACER

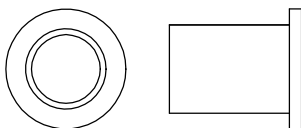

026-01M0240  
1 3/8" ALUMINUM  
FLATHEAD CAP

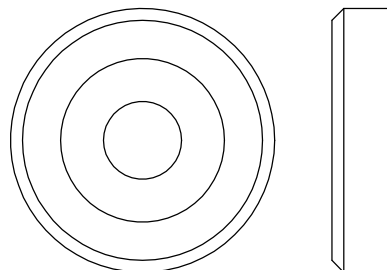

**026-01M0239**  
1 5/8" ALUMINUM  
FLATHEAD CAP

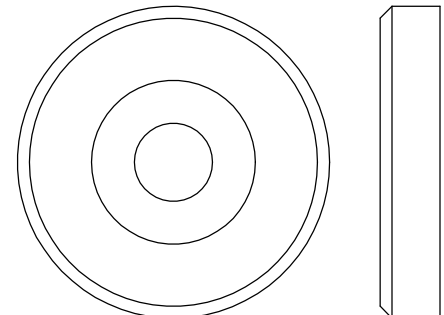

# OWNER'S MANUAL

## MAINTENANCE SCHEDULE

ROUTINE	COMMERCIAL / LIGHT COMMERCIAL MAINTENANCE	HOME MAINTENANCE	LATEST DATE ENTRY																				
Inspect; Links, Pull Pins, Snap Locks, Swivels, Weight Stack Pins	DAILY	WEEKLY																					
Clean; Upholstery	DAILY	WEEKLY																					
Inspect; Cables or Belts and their tension	DAILY	WEEKLY																					
Inspect; Accessory Bars, and Handles	WEEKLY	3 MONTHS																					
Inspect; All Decals	WEEKLY	3 MONTHS																					
Inspect; All Nuts and Bolts, Tighten if needed	WEEKLY	3 MONTHS																					
Inspect; Anti-Skid Surface	WEEKLY	3 MONTHS																					
Clean & Lubricate; Guide Rods with a Teflon (PTFE) based lubricant (Superlube)	MONTHLY	3 MONTHS																					
Lubricate; Seat Sleeves, Turcite Bushings, Linear Bearing	MONTHLY	3 MONTHS																					
Clean and Wax; All Glossy Finishes	6 MONTHS	YEARLY																					
Repack with Grease; Linear Bearings	6 MONTHS	YEARLY																					
Replace; Cables, Belts and Connecting Parts	YEARLY	3 YEARS																					

*Your equipment comes with a commercial maintenance decal.  
For personal, in home use, please follow the home maintenance schedule listed above.*

***Never use ammonia, acid-based, or petroleum-based solvents on any portion of the machine as it may damage the finish.***

# OWNER'S MANUAL

## **HOIST FITNESS SYSTEMS GENERAL MAINTENANCE INFORMATION**

### **Links, Pull-Pins, Snap Hooks, Swivels, Weight Stack Pins:**

- \*Check all pieces for signs of visible wear or damage.
- \*Check springs in snap hooks and pull-pins for proper tension and alignment.
- \*If the spring sticks or has lost its rigidity, replace it immediately.

### **Upholstery:**

- \*To ensure prolonged upholstery life and proper hygiene, all upholstered pads should be wiped down with a damp cloth after every workout.
- \*Periodically take the time to use a mild soap or an approved vinyl upholstery cleaner to deter the onset of cracking or drying. Avoid using any abrasive cleaners or cleaners not intended for use on vinyl.
- \*Replace ripped or worn upholstery immediately.
- \*Keep sharp or pointed objects clear of all upholstery.

### **Decals:**

- \*Inspect and familiarize yourself with any safety warnings or other user information posted on each decal.

### **Nuts and Bolts:**

- \*Inspect all nuts and bolts for any loosening and tighten if needed.
- \*Go through a re-tightening sequence periodically to ensure that all hardware is tensioned proper.

### **Anti-Skid Surfaces:**

- \*These surfaces are designed to supply secure footing and need to be replaced if they appear worn or become slippery.

### **Belts and Cables:**

- \*Hoist uses only high quality belt, and mil-spec cables.
- \*Visually inspect the belts and cables for fraying, cracking, peeling or discoloration.
- \*While the machine is not in use, carefully run your fingers along the belt or cable to feel for thinning or bulging areas.
- \*Replace belts and cables immediately at the first signs of damage or wear. Do not use equipment until belts or cables have been replaced.

### **Belt and Cable Tension:**

- \*Referring to the Owners Manual, when belts or cables are used check all bolts attachments to be sure they are properly attached.
- \*Check slack in cables and re-adjust cable tension if needed.

### **Seat Sleeves, Guide Rods:**

- \*Wipe down adjusting tubes with a dust free rag before applying lubricant.
- \*Lubricate seat sleeves and Guide Rods with a Silicon or Teflon based lubricant spray.

### **Linear Bearings:**

- \*Referring to the Owners Manual carefully disassemble the bearing from its housing and place a finger full of light grease (lithium, super lube, etc.) into the inside of the bearing. Using your finger, press the grease into the ball-bearings and their tracks. repeat until the ball-bearing tracks are full of grease. Insert the shaft back into the bearing and wipe off excess grease.

**PLEASE KEEP THIS FOR YOUR RECORDS**

# OWNER'S MANUAL

## WEIGHT TRAINING TIPS

Use this manual to guide you through the basic exercises you can perform on your HD-3000 HOIST® Fitness System. To gain maximum results and avoid possible injury, consult a fitness professional to develop your complete exercise program.

Always consult your physician before starting any exercise program.

To be successful in your exercise program, it is important to develop an understanding of the basic principles of strength training. Now that you have your HD-3000 HOIST® Fitness System, it is only natural that you want to get started immediately. First, determine a set of realistic goals and objectives for yourself. By deciding on an exercise plan that is right for you prior to starting, you will contribute significantly to your success.

Warm up properly before engaging in weight resistance training. Stretching, yoga, jogging, calisthenics or other cardiovascular exercise can help prepare your body for the heavier workload of lifting weights.

Learn how to perform the exercise correctly before using heavy weight. Correct form is important to avoid injury and to ensure that you work the proper muscle groups.

Know your limitations. If you are new to weight training or are embarking on an exercise regimen after a long layoff, start slowly and build foundational strength over a longer period of time.

Pay attention to your breathing. Exhale when you exert is a general rule of thumb. Never hold your breath.

**Enjoy your HD-3000 HOIST® Fitness System!**

# OWNER'S MANUAL

## WEIGHT RATIOS

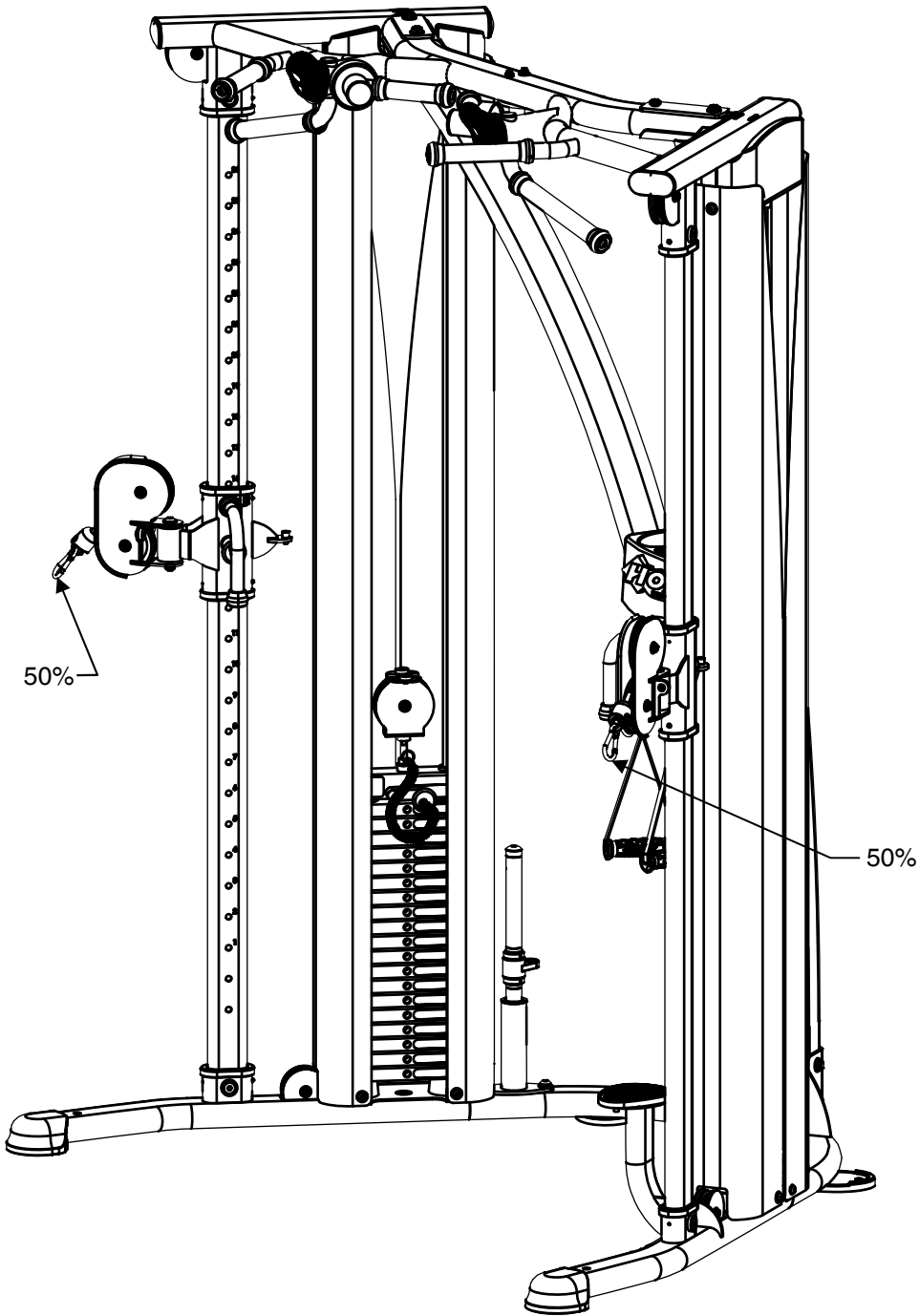

WEIGHT STACK

NUMBER OF PLATES	100%	50%
1	10	5
2	20	10
3	30	15
4	40	20
5	50	25
6	60	30
7	70	35
8	80	40
9	90	45
10	100	50
11	110	55
12	120	60
13	130	65
14	140	70
15	150	75
16	160	80
17	170	85
18	180	90
19	190	95
20	200	100

The above chart shows the standard weight stack for this unit. The weights listed are approximate. HOIST reserves the right to modify the machine without prior notice.





# OWNER'S MANUAL

## **HOIST FITNESS SYSTEMS** **LIMITED LIFETIME WARRANTY**

Hoist Fitness Systems warrants this product to the **original purchaser** to be free from defects in workmanship and/or materials under normal use or service. If at any time a component part is defective, Hoist Fitness Systems shall repair or replace it (at Hoist Fitness Systems option) within a reasonable period of time. This warranty does not cover costs of removal, transportation or reinstallation. This warranty shall not apply if the defect was caused by misuse, neglect or normal wear and tear.

**WARRANTY CLAIMS. All claims require: Model number, Serial number, Date of installation, and any information supporting the existence of the alleged defect.**

To complete Warranty Registration visit:  
[www.HOISTFITNESS.com](http://www.HOISTFITNESS.com)  
and click on the Warranty Registration link

Starting from the original date of purchase, normal wear and tear shall be considered as the following:

**COMMERCIAL USE:** All malfunctions of upholstery, grips, and coatings that occur up to one year; all malfunctions of belts, or **cables** up to one year; all malfunctions of pulleys, bearings, or bushings that occur up to three years. The frame and body components are warranted for ten years, with structural moving parts warranted for five years.

**LIGHT COMMERCIAL USE:** All malfunctions of upholstery, grips, and coatings that occur up to one year; all malfunctions of belts, or **cables** up to one year; all malfunctions of pulleys, bearings, or bushings that occur up to three years. The frame and body components are warranted for ten years, with structural moving parts warranted for five years.

**HOME USE:** All malfunctions of grips, paint, and chrome that occur up to ten years; all malfunctions of electronic components, belts, **cables**, or upholstery that occur up to ten years; all malfunctions of pulleys, bearings, or bushings that occur up to ten years. The frame and all welded components are warranted for the life of the product.

**PLEASE NOTE THAT NOT ALL HOIST PRODUCTS ARE MADE FOR COMMERCIAL USE.** Refer to the instructions page of your owners manual or consult with you fitness product dealer to establish if a product is made for commercial use or not. Using a non-commercial product in a commercial setting can result in serious injury or death! Hoist Fitness Systems sole responsibility shall be to repair or replace the component within the terms stated above. Hoist Fitness Systems shall not be liable for any loss or damage of any kind including any incidental or consequential damages resulting, directly or indirectly from any warranty expressed or implied or any other failure of this product.

**LIGHT COMMERCIAL USE:** Our Light Commercial warranty applies to facilities that **DO NOT** charge monthly membership dues and where the equipment would be used by **no more than 50** people per day. Examples of Light Commercial facilities include hotels, apartment complexes, personal training studios, fire stations, police stations, etc., that meet the criteria stated above.

**WHAT IS NOT COVERED BY THIS WARRANTY:** Hoist's sole obligation under this warranty is limited to either repair or replacement of parts, subject to the additions below. This warranty neither assumes nor authorizes any person to assume obligations other than expressly covered by this warranty.

**NO CONSEQUENTIAL DAMAGES:** Hoist is not responsible for economic loss; profit loss; or special, indirect, or consequential damages.

**WARRANTY IS NOT TRANSFERABLE:** This warranty is not assignable and applies only in favor of the original purchaser/user to whom delivered. Any such assignment or transfer shall void the warranties herein made and shall void all warranties, expressed, implied or statutory, except the one (1) and five (5) year warranties described above. These warranties are exclusive and in lieu of all other warranties, including implied warranty and merchantability or fitness for a particular purpose. There are no warranties which extend beyond the description on the face hereof.

**TRANSPORTATION COSTS:** Hoist will accept parts covered under this warranty freight collect, provided that shipment has received prior approval. Hoist is not responsible for any other transportation costs, but will ship freight collect parts either repaired or replaced under these warranties.

Hoist Fitness Systems  
11900 Community Rd.  
Poway, CA. 92064  
(800)548-5438

**PLEASE KEEP THIS FOR YOUR RECORDS**